

Cooling tower with counter flow arrangement and axial fan

First part: analysis of pressure drop and heat and mass transfer on air side

Main subscripts :

su : « supply »

ex : « exhaust »

n : « nominal »

CT : « cooling tower »

Jk : numerical index (to be replaced by 01, 02, etc. to designate a specific component)

lw: “*liquid water*”

a: “*dry air*”

ln: “*logarithmic*”

p: “*at constant pressure*”

f : « fictitious »

g : “*water vapor*”

regr: “*regression*”

1. Information contained in the ASHRAE “primary” toolkit [1]

(EES file: “JL221124-01 completed JL221114-01 nominal conditions toolkit”)

1.1 Nominal conditions

Wet bulb at tower supply:

$$t_{wb,CTjk,su,\bar{n}} = 25.6 \text{ [C]}$$

$$\text{Approach}_{CTjk,n} = 3.8 \text{ [K]}$$

with

$$\text{Approach}_{CTjk,n} = t_{lw,CTjk,ex,\bar{n}} - t_{wb,CTjk,su,n}$$

$$\text{Range}_{CTjk,n} = 5.6 \text{ [K]}$$

with

$$\text{Range}_{CTjk,n} = t_{lw,CTjk,su,\bar{n}} - t_{lw,CTjk,ex,n}$$

Dry bulb: 30 C, atmospheric pressure: 101325 Pa.

This gives:

$$c_{p,CTjk,su,n} = 1040 \text{ [J/kg-K]}$$

$$\omega_{CTjk,su,n} = 0.01896 \text{ [-]}$$

$$p = 101325 \text{ [Pa]}$$

$$\rho_{CTjk,su,n} = 1.151 \text{ [kg/m}^3\text{]}$$

$$RH_{CTjk,su,n} = 0.706 \text{ [-]}$$

$$t_{CTjk,su,n} = 30 \text{ [C]}$$

$$t_{wb,CTjk,su,n} = 25.6 \text{ [C]}$$

$$v_{CTjk,su,n} = 0.885 \text{ [m}^3\text{/kg]}$$

1.2 Nominal liquid water flow rate

This nominal flow rate is imposed by other nominal conditions (nominal cooling power and nominal range):

$$\dot{M}_{lw,CTjk,n} = \frac{\dot{Q}_{CTjk,n}}{c_{lw} \cdot \text{Range}_{CTjk,n}}$$

Example: for a typical cooling tower of 1 MW, one gets:

$$\dot{M}_{lw,CTjk,n} = 42.65 \text{ [kg/s]}$$

NB: this is a convenient simplification: the actual water flow rate is actually (*sightly*) decreasing from supply to exhaust of the cooling tower. A small part of the cooling power is, therefore, provided by the *make-up water*.

1.3 Nominal dry air flow rate

Typical values are presented in **Figure 1**. They are extracted from manufacturers catalogues.

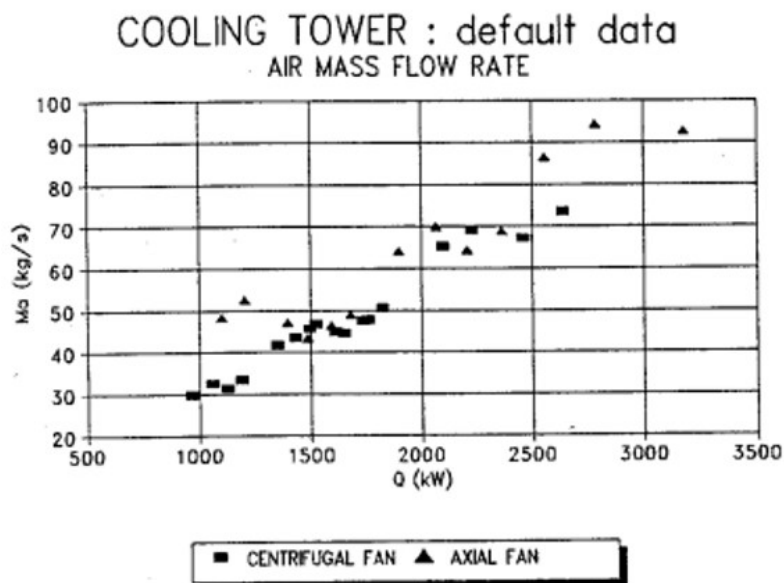

Figure 1: Dry air flow rate as function of thermal power in nominal conditions

In nominal conditions, the air flow rate of a “typical” cooling tower can be correlated with thermal power according to the following linear regression:

$$\dot{M}_{a,CTjk,n} = a_{CTjk,n} \cdot \dot{Q}_{CTjk,n} + b_{CTjk,n}$$

NB: This is the **dry** air flow rate (but, of course, the distinction between **dry** and **wet** air flow rates has little impact in such regression)...

With, if axial fan,

$$a_{CTjk,n} = 0.0000265 \text{ [kg/J]}$$

$$b_{CTjk,n} = 11.7 \text{ [kg/s]}$$

(Axial fans are preferably selected for larger cooling towers. They also allow using relatively larger air flow rates).

One can identify a typical air/water mass flow rate ratio (Figure 2).

$$\text{Mflowratio}_{CTjk,n} = \frac{\dot{M}_{a,CTjk,n}}{\dot{M}_{lw,CTjk,n}}$$

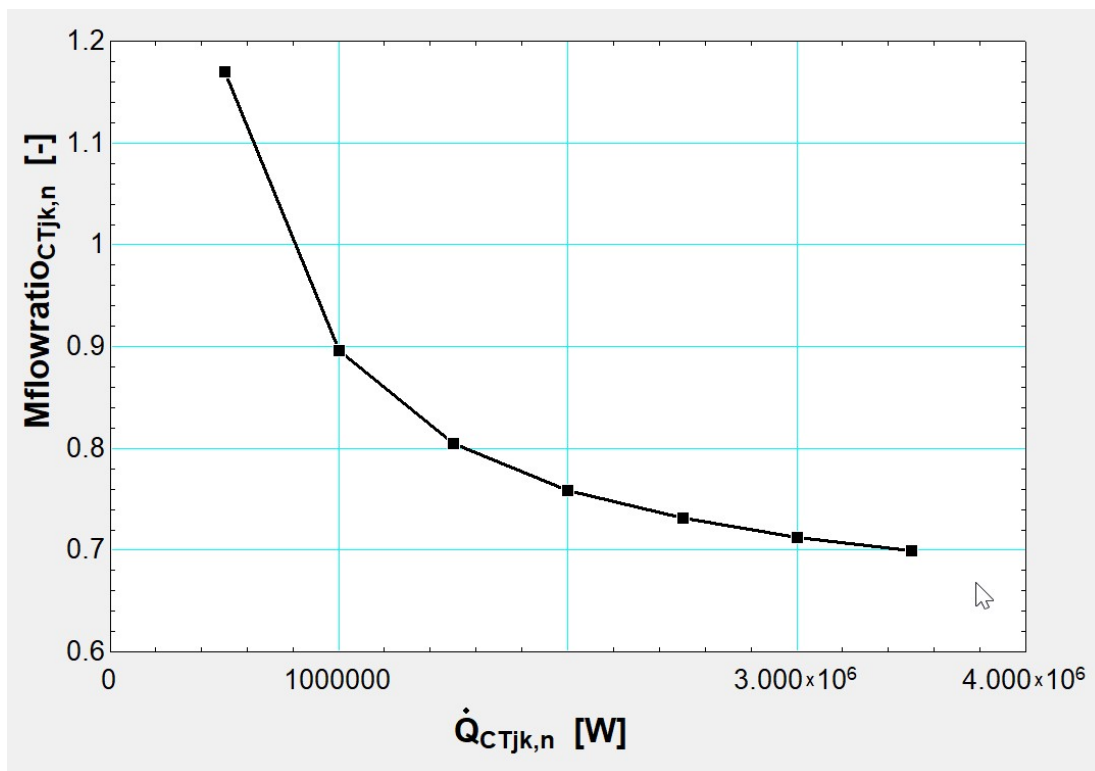

Figure 2: Variation of the air/water mass flow rate ratio suggested by the ASHRAE toolkit

Example: for a typical cooling tower of 1 MW, equipped with axial fan, one gets:

$$\dot{M}_{CTjk,n} = 38.2 \text{ [kg/s]} \quad \dot{V}_{CTjk,n} = 33.81 \text{ [m}^3\text{/s]}$$

And

$$\text{Mflowratio}_{CTjk,n} = 0.8957 \text{ [-]}$$

1.4 Nominal fan power

The typical values presented in **Figure 3** are also extracted from manufacturers catalogues.

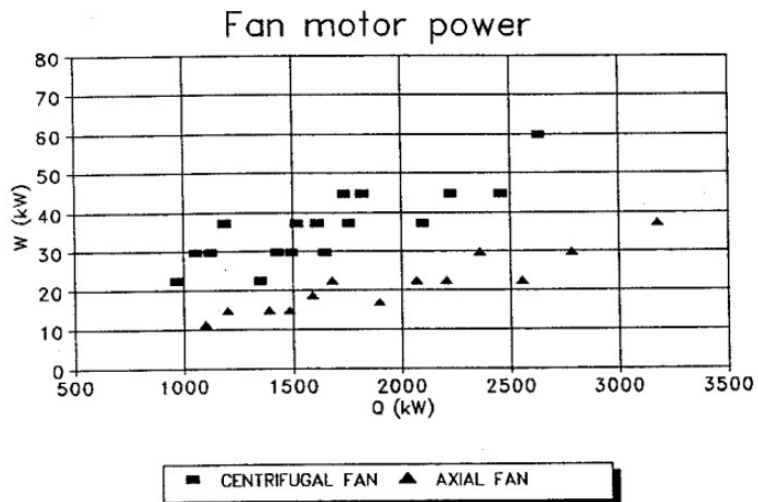

Figure 3: Fan power as function of thermal power in nominal conditions

In nominal conditions, the fan power of a “typical” cooling tower can be correlated with thermal power according to the following linear regression:

$$\frac{\dot{W}_{CTjk, fan, n}}{W} = e_{CTjk, n} \cdot \frac{\dot{Q}_{CTjk, n}}{W} + f_{CTjk, n}$$

with,

if axial fan,

$$e_{CTjk, n} = 0.01077 \text{ [-]}$$

$$f_{CTjk, n} = 261 \text{ [-]}$$

Example: for a typical cooling tower of 1 MW, equipped with axial fan, one gets:

$$\dot{W}_{CTjk, fan, n} = 11031 \text{ [W]}$$

1.5 Nominal pressure drop on air side

The two variables already identified (air flow rate and corresponding fan power in nominal conditions) are related to each other by the following equation:

$$\dot{W}_{CTjk,n} = \dot{V}_{CTjk,n} \cdot \frac{\Delta p_{CTjk,n}}{\eta_{fan,CTjk,n}}$$

with

$$\dot{V}_{CTjk,n} = \dot{M}_{a,CTjk,n} v_{CTjk,su,n}$$

$$\eta_{fan,CTjk,n} = 0.5 \text{ [-]}$$

(hypothetical!)

(and with **dry** mass air flow rate associated to its **specific** volume).

This gives the curves of **Figures 4 and 5**.

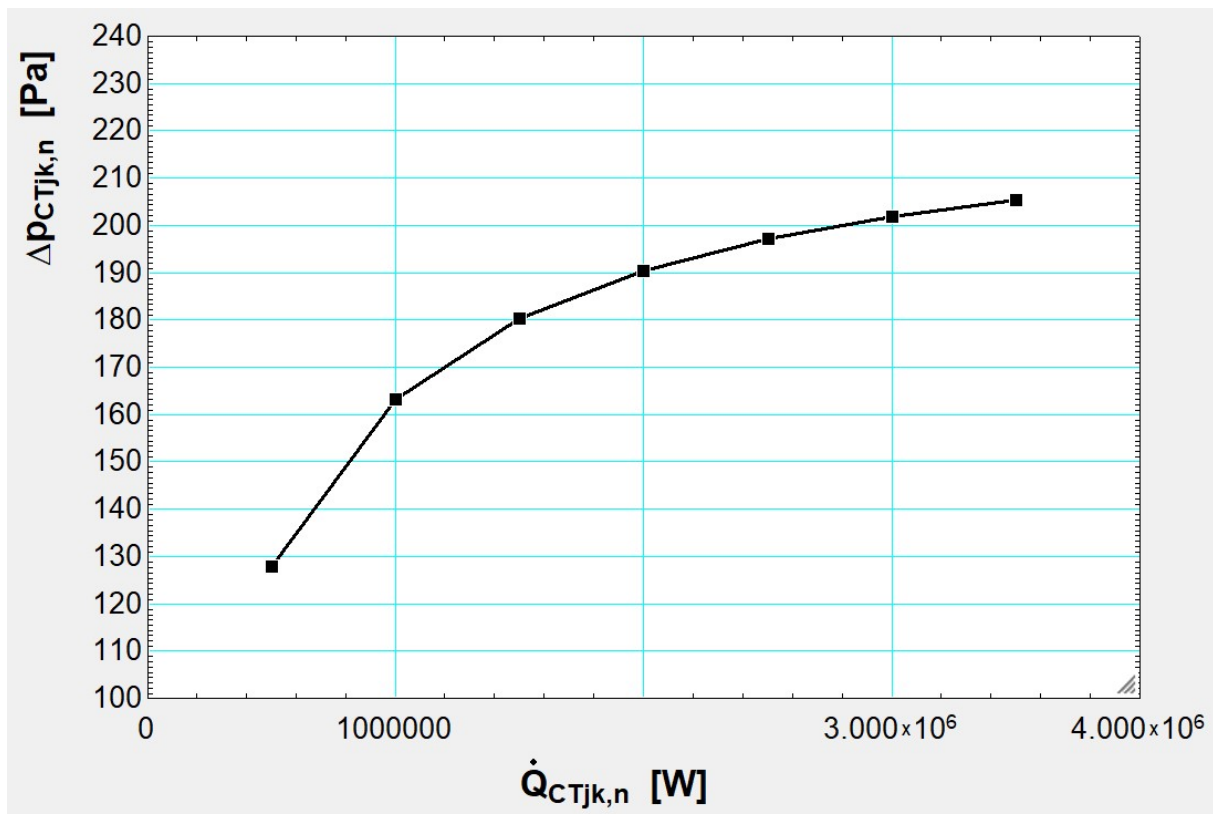

Figure 4: Air side pressure drop as function of *nominal cooling power*, according to the ASHRAE toolkit



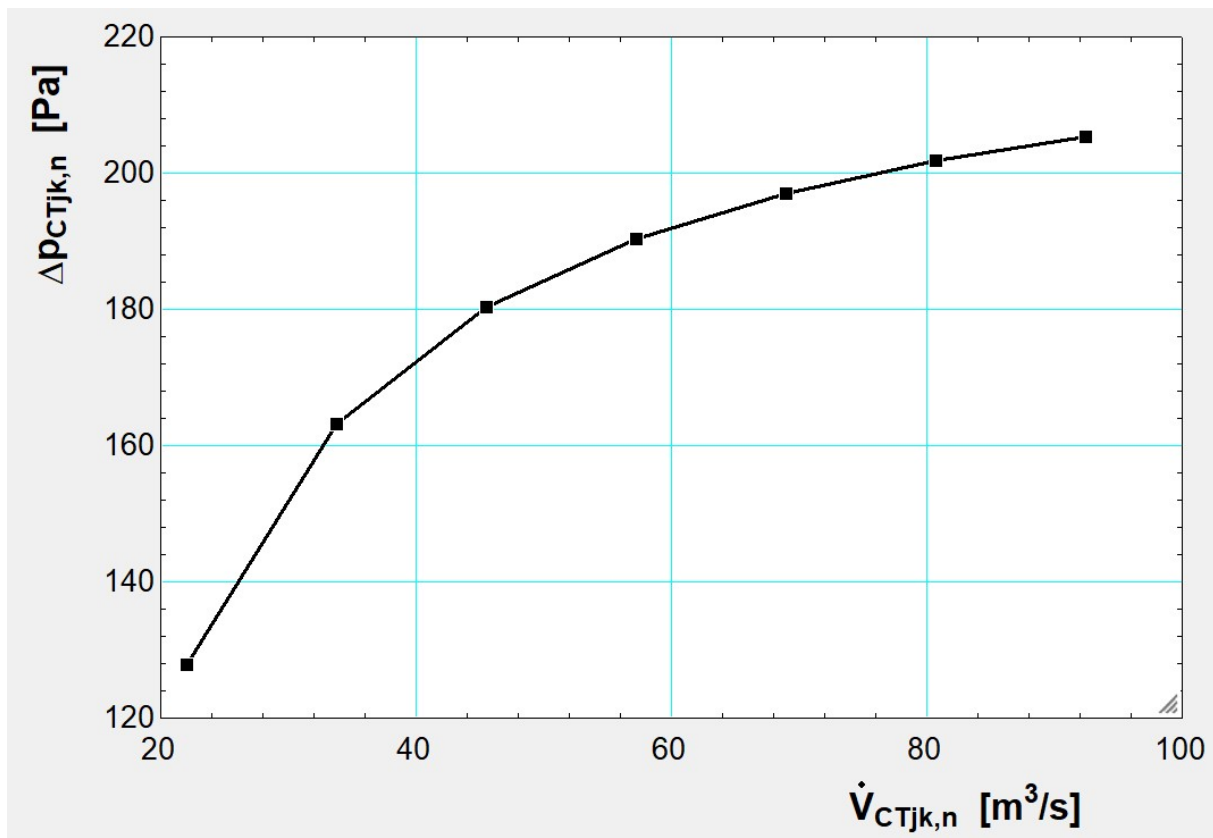

Figure 5: Air side pressure drop as function of *nominal volume flow rate*, according to the ASHRAE toolkit

Example: for a typical cooling tower of 1 MW, equipped with axial fan, one gets

$$\Delta p_{CTjk,n} = 163.1 \text{ [Pa]}$$

If this pressure drop is supposed to occur *through the padding* of the cooling tower only, it can be defined *as if* produced through a *fictitious tube*:

$$\Delta p = f \cdot \frac{L}{D_h} \cdot \rho \cdot \frac{vel^2}{2}$$

With f: “Moody friction factor” (adimensional)

L: “tube length” (depending from the channels shape and from the padding height)

D_h: “hydraulic diameter” (depending from the channels shape *and also from the **water flow rate!***)

rho: “humid air density”

vel: "average velocity" *inside the tube*

$$\text{vel} = \frac{\dot{V}}{A_{\text{free}}}$$

A_{free} : "cross free area" (depending from the shape of the channels *and also from the **water flow rate!***)

In the ASHRAE primary toolkit, no information is given about any typical geometry of the cooling tower.

Therefore and at this stage, one can only identify a global "**friction coefficient**":

$$fL \backslash D_{\text{free}}^2 = f \cdot \frac{L}{D_h \cdot A_{\text{free}}^2} \quad [1/\text{m}^4]$$

$$\Delta p = fL \backslash D_{\text{free}}^2 \cdot \rho \cdot \frac{\dot{V}^2}{2}$$

The coefficient " **$fL \backslash D_{\text{free}}^2$** " is plotted as functions of the nominal cooling power and of the nominal air flow rate in **Figures 6** and **7**.

NB:

- 1) These plots are supposed to concern *a set of different* cooling towers working in *same reference conditions*.
- 2) Nothing is yet said here about the possible behaviour of *a same cooling tower* submitted to some *variations of both air and water flow rates*.
- 3) In turbulent regime, the friction factor "f" is expected to vary very little, but the free area is expected to be a *decreasing function of the water flow rate*...

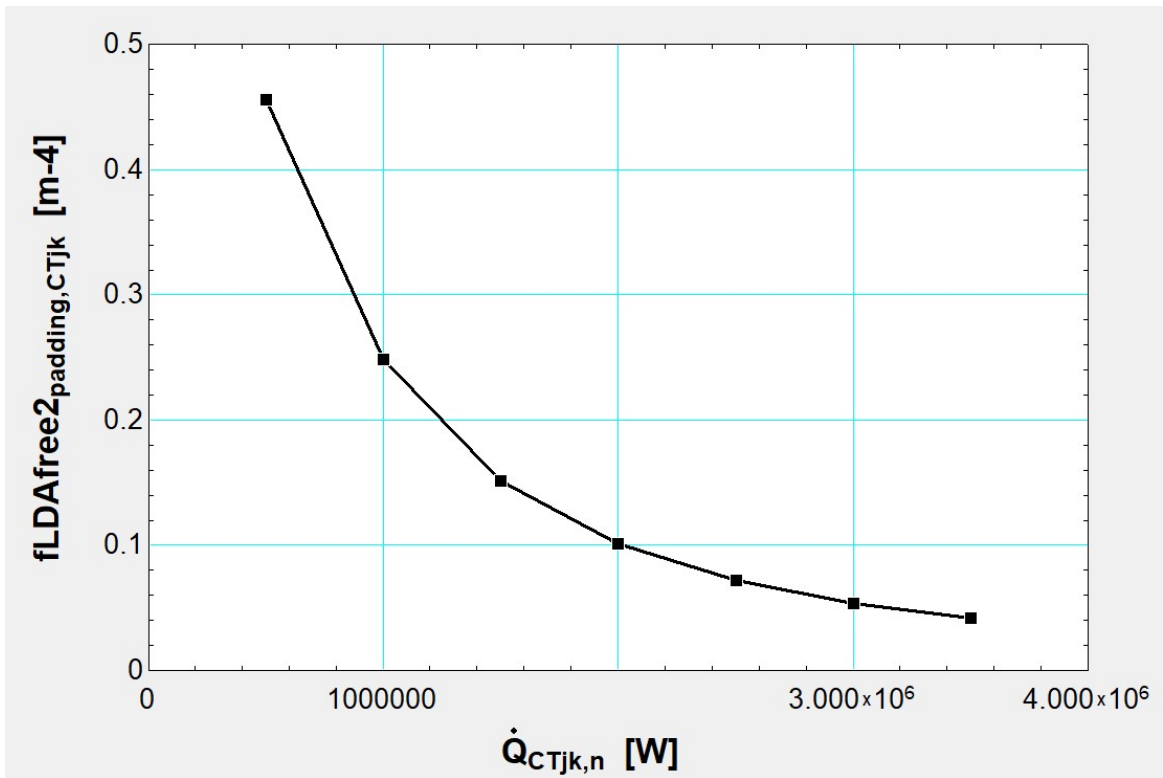

Figure 6: Nominal friction coefficient as function of the **nominal** cooling power

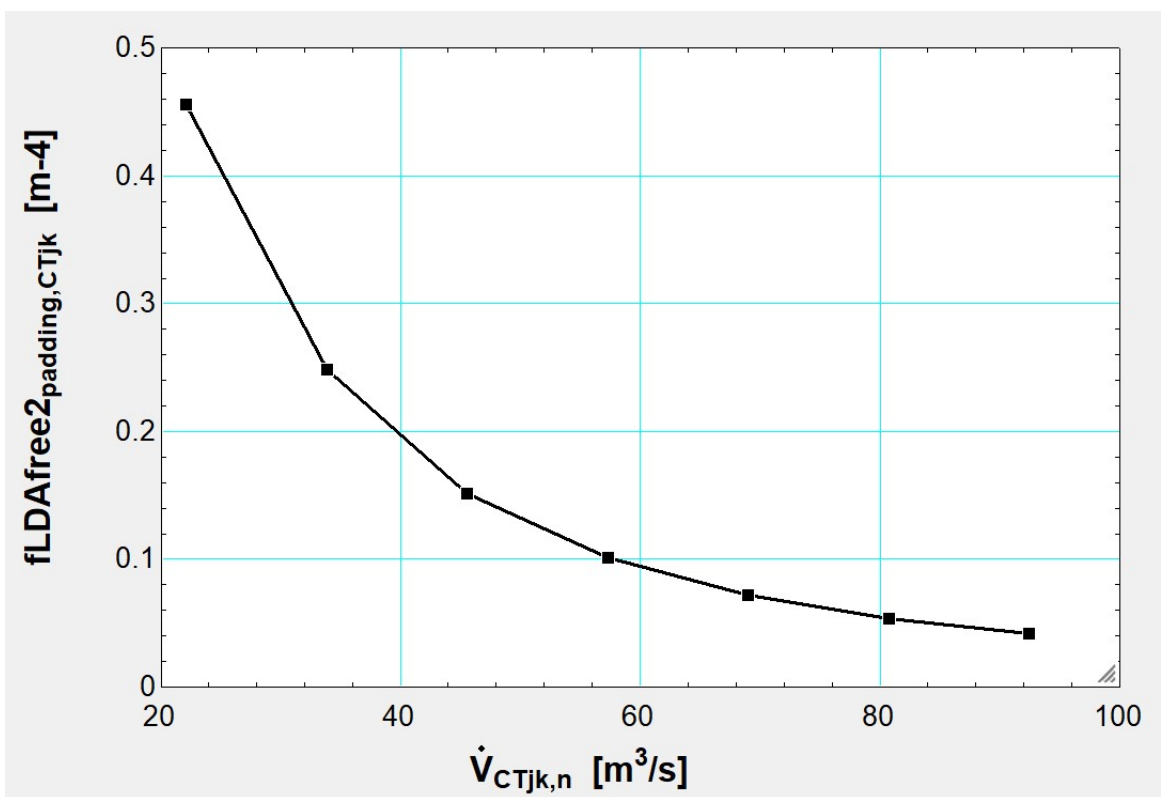

Figure 7: Nominal friction coefficient as function of the **nominal** volume flow rate

Example: for a typical cooling tower of 1 MW, equipped with axial fan,

$$HFVA^2_{padding,CTjk} = 0.248 \text{ [m}^{-4}\text{]}$$

(For **that** padding type, **that** length, **that** hydraulic diameter, **that** free area and **that** associated **air/water mass flow rate ratio!**)

1.6 Nominal heat transfer coefficient

Exhaust air state:

$$h_{CTjk,ex,n} = h_{CTjk,su,n} + \frac{\dot{Q}_{CTjk,n}}{\dot{M}_{CTjk,n}}$$

(NB: This stays as a convenient approximation: the small part of cooling power provided by the *make-up water* is neglected.)

DELTA_t:

$$\Delta t_{ln,CTjk,n} = \frac{\Delta tO_{CTjk,n} - \Delta tL_{CTjk,n}}{\ln \left[\frac{\Delta tO_{CTjk,n}}{\Delta tL_{CTjk,n}} \right]}$$

with

$$\Delta tO_{CTjk,n} = t_{lw,CTjk,su,n} - T_{wb,CTjk,ex,n}$$

$$\Delta tL_{CTjk,n} = t_{lw,CTjk,ex,n} - t_{wb,CTjk,su,n}$$

Fictitious heat transfer coefficient:

$$AU_{f,CTjk,n} = \frac{\dot{Q}_{CTjk,n}}{\Delta t_{ln,CTjk,n}}$$

(Here also, as a fair approximation, the small variation of water flow rate along the cooling tower is neglected)

Actual (sensible) heat transfer coefficient:

$$AU_{CTjk,n} = AU_{f,CTjk,n} \frac{c_{p,CTjk,n}}{c_{p,f,CTjk,n}}$$

with

$$c_{p,CTjk,n} = c_{p,a} + \omega_{CTjk,su,n} \cdot c_{p,g}$$

And

Air fictitious specific heat:

$$c_{p,f,CTjk,n} = \frac{h_{CTjk,ex,n} - h_{CTjk,su,n}}{T_{wb,CTjk,ex,n} - t_{wb,CTjk,su,n}}$$

(Both specific heat, and mainly the *fictitious* one, are actually *varying* along the cooling tower; this last average value is selected in such a way to close the *global energy balance*).

Typical values are presented in **Figure 8**.

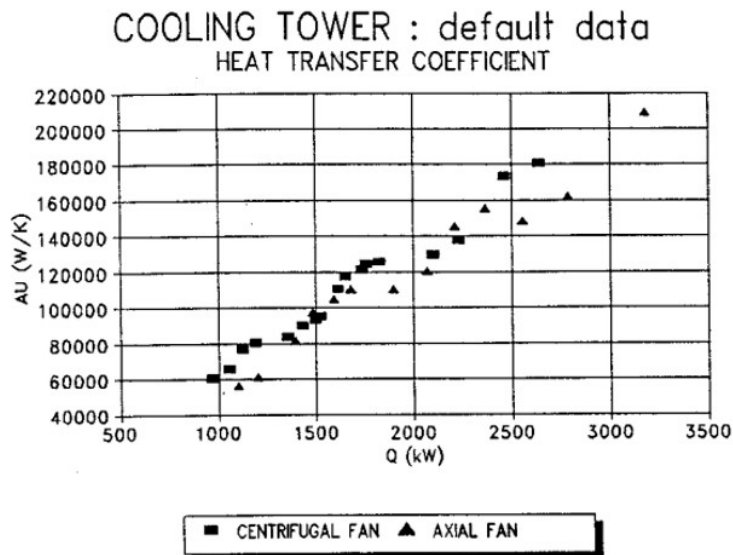

Figure 8: heat transfer coefficient as function of thermal power in nominal conditions

This heat transfer coefficient can be correlated to the nominal cooling power through the following linear regression:

$$AU_{CTjk,n} = c \cdot \dot{Q}_{CTjk,n} + d$$

$$c = 0.06667 \text{ [K}^{-1}\text{]}$$

$$d = -10642 \text{ [W/K]}$$

With axial fan

By combining this new regression with the first one, relating air flow rate to nominal cooling power (**Figure 1**), one gets the result plotted in **Figure 9**.

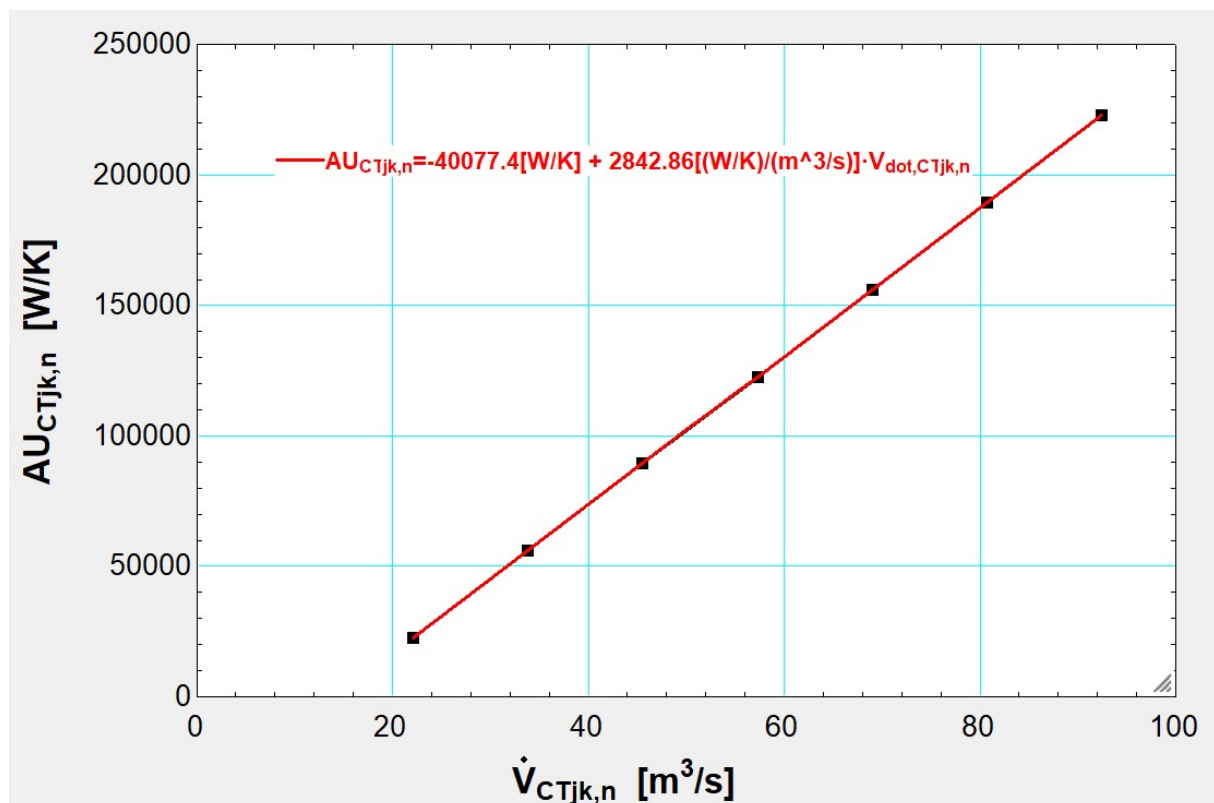

Figure 9: Nominal heat transfer coefficient as function of the nominal air flow rate

NB: this should *not* be confounded with the relationship (not yet considered) between the heat transfer coefficient and the air flow rate *of a same cooling tower*...

Example: for a typical cooling tower of 1 MW, one gets, still in nominal conditions:

$$c_{p,f,CTjk,n} = 4792 \text{ [J/kg-K]}$$

$$AU_{CTjk,n} = 56083 \text{ [W/K]}$$

$$AU_{f,CTjk,n} = 258506 \text{ [W/K]}$$

For a given cooling tower, the actual global heat transfer coefficient can be described as follows:

$$AU = A_{wet} \cdot U \text{ [W/K]}$$

With A_{wet} : “wet transfer area” [m²]

$$A_{wet} = \epsilon_{spreading} \cdot A_{dry}$$

$\epsilon_{spreading}$: “spreading effectiveness” (increasing function of the water flow rate) [-]

A_{dry} : “Dry transfer area”

$$A_{dry} = \alpha \cdot \text{Volume}$$

α : “padding compactness” [1/m]

$$U = h_c \text{ [W/m}^2\text{K]}$$

h_c : “convective heat transfer coefficient”

$$h_c = \text{Nusselt} \cdot k / D_h$$

k : “air thermal conductivity” (currently around 0.025 [W/m-K])

D_h : “hydraulic diameter” [m]

$$\text{Nusselt} = j \cdot \text{Reynolds} \cdot \text{Prandtl}^{(1/3)} \text{ [-]}$$

j : “Colburn number [-]

$$\text{Reynolds} = \text{vel} \cdot D_h / \nu \text{ [-]}$$

vel : “average velocity” **inside** the channels [m/s]

ν : “cinematic viscosity” (currently around 0.15E-4 [m²/s])

This gives:

$$AU_{CTjk,n} = j \text{PrkAwet} \nu A_{free} \dot{V}_{CTjk,n}$$

With the global “**Colburn coefficient**”:

$$j \text{PrkAwet} \nu A_{free} = j \cdot \text{Prandtl} \cdot \frac{k}{v} \cdot \alpha \cdot \text{Volume} \cdot \frac{\epsilon_{spray}}{A_{free}}$$

Again here, the very limited information available in the ASHRAE toolkit doesn't allow yet to identify most of these different variables.

One may only expect the following tendencies:

1) AU proportional to the product "Alpha*volume*j*V_dot"

With, typically, the Colburn number "j" being a (slowly) decreasing function of V_dot and, therefore,

2) AU proportional to "V_dot^n" with the exponent "n" (slightly) lower than 1.

3) AU (slowly) increasing function of the water flow rate (thanks to the growing spraying effectiveness)...

The other terms have the following meanings:

Prandtl · $\frac{k}{v}$ Combination of *humid air properties* (almost constant in most current conditions, but with a slight effect of atmospheric pressure)

$\alpha \cdot \text{Volume}$ *Constant* combination of geometrical characteristics of **this** cooling tower

$\frac{\varepsilon_{\text{spray}}}{A_{\text{free}}}$ Combination of other geometrical characteristics, *increasing function of the water flow rate...*

Nominal values of the global "Colburn coefficient" are plotted as functions of the *nominal* cooling power and of the *nominal* air flow rate in **Figures 10** and **11**.

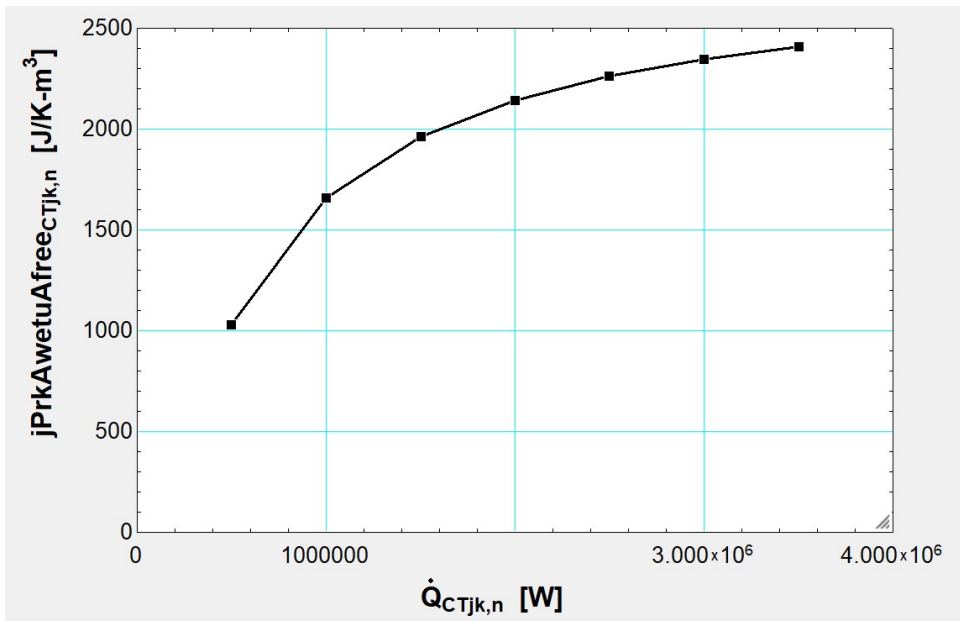

Figure 10: Nominal Colburn coefficient as function of the nominal cooling power

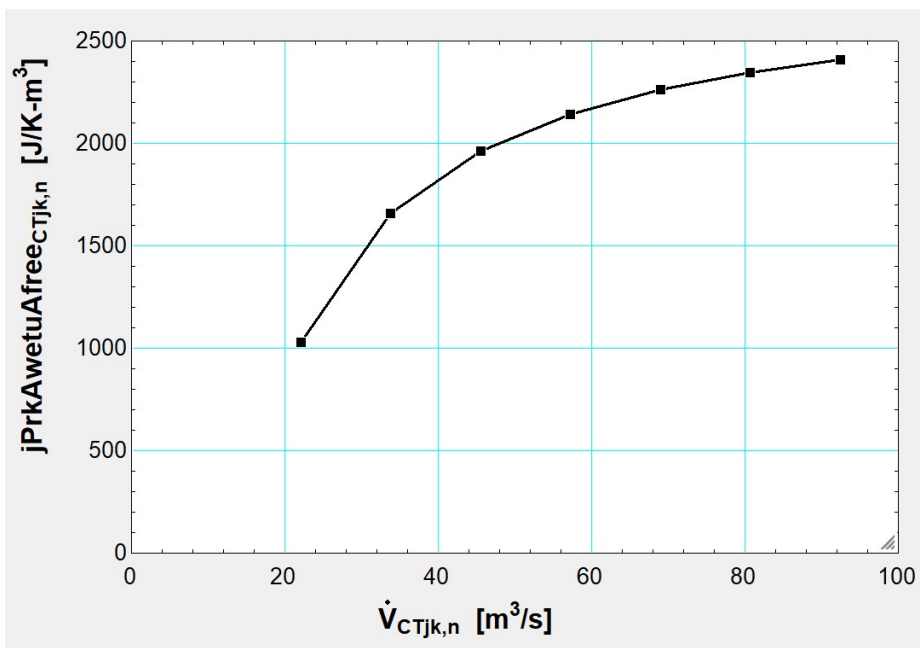

Figure 11: Nominal Colburn coefficient as function of the nominal air flow rate

Example: for a typical cooling tower of 1 MW, one gets, still in nominal conditions:

$$jPrkAwetuAfree_{CTjk,n} = 1657 \text{ [J/K-m}^3\text{]}$$

2. Information given by a first manufacturer [2]

2.1 Catalogue data

Sketches of BAC “RCT” cooling towers are presented in **Figure 12**.

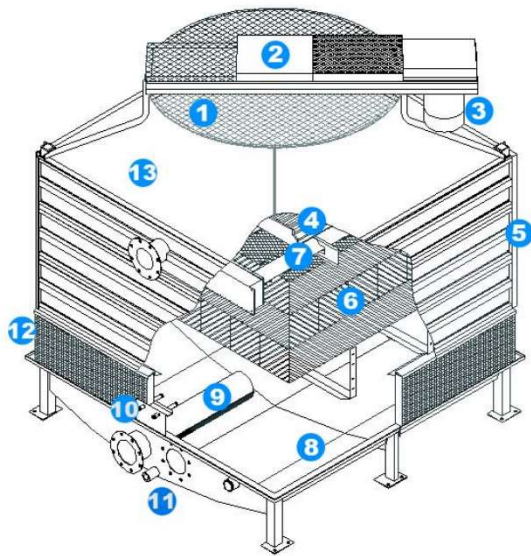

Single Fan Units - Square Box Sizes

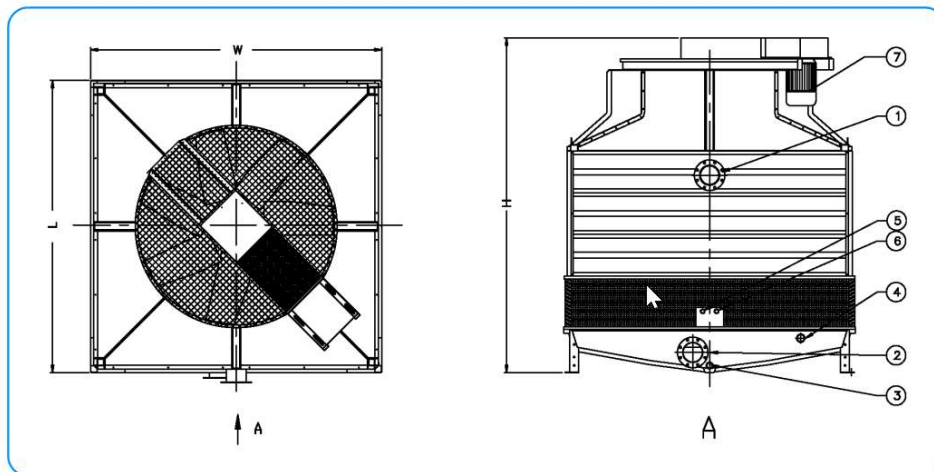

1. Water Inlet; 2. Water Outlet; 3. Drain; 4. Overflow; 5. Make-Up; 6. Quick Fill; 7. Fan Motor.

Figure 12: The BAC “RCT” cooling tower

It appears that the **padding** height corresponds here to about 25 % (or, may be, a little more) of the **tower** height.

The main characteristics given by the manufacturer are presented in **Table 1**.

Model	W	L	H	Shipping Weight (kg)	Operating Weight (kg)	Fan Motor (kW)	Air Flow (m ³ /s)	Fan (mm)	Inlet ND (mm)	Outlet ND (mm)	Drain ND (mm)	Overflow ND (mm)	Makeup ND (mm)	Quick-fill ND (mm)
RCT-2118-1	2284	2284	3252	1000	2675	5,5	15,4	1524	150	150	50	50	20	20
RCT-2129-1	2284	2284	3252	1000	2675	7,5	17,3	1524	150	150	50	50	20	20
RCT-2142-1	2589	2589	3326	1250	3375	5,5	18,5	1829	150	150	50	80	20	20
RCT-2156-1	2589	2589	3326	1250	3375	7,5	20,4	1829	150	150	50	80	20	20
RCT-2183-1	2894	2894	3413	1550	4125	7,5	23,9	2134	200	200	50	80	20	20
RCT-2208-1	2894	2894	3413	1550	4125	11	27,2	2134	200	200	50	80	20	20
RCT-2238-1	3198	3198	3646	1800	4850	11	31,2	2134	200	200	50	80	40	40
RCT-2262-1	3198	3198	3646	1800	4850	15	34,2	2134	200	200	50	80	40	40
RCT-2299-1	3499	3499	3810	2100	5700	15	39,0	2438	200	250	50	80	40	40
RCT-2320-1	3499	3499	3810	2100	5700	18,5	41,8	2438	200	250	50	80	40	40

Table 1: Main characteristics of the RCT cooling towers

The “biggest” cooling tower (RCT-2320-1) has the following characteristics:

Main sizes:

W_tower=3.499 [m]

L_tower=3.499 [m]

H_tower=3.810 [m]

Fan power:

W_dot_fan=18.5 [kW]

Volume air flow rate:

V_dot=41.8 [m³/s]

2.2 Analysis

All cooling towers of this catalogue [2], are supposed to be sized for the following nominal regime:

$$t_{lw,CTjk,su,\bar{n}} = 35 \text{ [C]}$$

$$t_{lw,CTjk,ex,\bar{n}} = 30 \text{ [C]}$$

$$t_{wb,CTjk,su,\bar{n}} = 21 \text{ [C]}$$

NB: the nominal supply wet bulb temperature is here significantly lower than in the ASHRAE toolkit. This makes that the nominal cooling power

of a same cooling tower is expected to be here *higher* than suggested in the ASHRAE toolkit.

Other nominal data hypothetically considered:

$$p = 101325 \text{ [Pa]}$$

$$t_{CTjk,su,n} = 30 \text{ [C]}$$

Mass flow ratio:

$$Mflowratio_{CTjk,n} = 1$$

Fan efficiency:

$$\eta_{fan,CTjk,n} = 0.5 \text{ [-]}$$

Air pressure drops upstream and downstream of the padding: neglected

This gives:

$$\Delta p_{padding,CTjk,n} = 221.3 \text{ [Pa]}$$

The nominal cooling power is here calculated as function of the water mass flow rate and of the range:

$$\dot{Q}_{CTjk,n} = \dot{M}_{lw,CTjk,n} \cdot c_{lw} \cdot Range_{CTjk,n}$$

With the water flow rate function of the air flow rate and of the (hypothetical) mass flow ratio:

$$\dot{M}_{lw,CTjk,n} = \frac{\dot{M}_{CTjk,n}}{Mflowratio_{CTjk,n}}$$

This gives:

$$\dot{M}_{CTjk,n} = 47.76 \text{ [kg/s]}$$

$$\dot{M}_{lw,CTjk,n} = 47.76 \text{ [kg/s]}$$

$$Q_{CTjk,n} = 999865 \text{ [W]}$$

$$AU_{CTjk,n}=32166 \text{ [W/K]}$$

These characteristics are obtained in **BAC nominal conditions**.

For a comparison with the typical data suggested by the ASHRAE toolkit, this cooling tower has to be submitted to **ASHRAE toolkit nominal conditions**, i.e. to a higher supply wet bulb temperature (EES file: “JL221115-01 JL221111-01 BAC cooling tower in toolkit conditions”):

Nominal conditions of the toolkit:

$$t_{wb,CTjk,su,\bar{n}} = 25.6 \text{ [C]}$$

$$t_{lw,CTjk,su,\bar{n}} = 35 \text{ [C]}$$

Heat transfer coefficient already identified:

$$AU_{CTjk,n,BAC} = 32166 \text{ [W/K]}$$

The actual cooling power produced by this tower in toolkit conditions is easy to identify by search on exhaust water temperature, until finding back this “correct” heat transfer coefficient, as shown in **Table 2** and in **Figure 11**.

¹ $t_{lw,CTjk,ex,n}$ [C]	² $AU_{CTjk,n}$ [W/K]	³ $AU_{CTjk,n,BAC}$ [W/K]	⁴ Approach _{CTjk,r} [K]	⁵ Range _{CTjk,n} [K]	⁶ $\dot{Q}_{CTjk,n}$ [W]	⁷ $t_{wb,CTjk,ex,n}$ [C]
31.03	37603	32166	5.426	3.974	785990	29.7
31.13	36147	32166	5.528	3.872	765707	29.61
31.23	34737	32166	5.631	3.769	745423	29.53
31.33	33371	32166	5.733	3.667	725139	29.44
31.44	32047	32166	5.836	3.564	704856	29.35
31.54	30762	32166	5.938	3.462	684572	29.26

Table 2: Identification of the cooling power in nominal conditions of the ASHRAE toolkit

The “correct” water exhaust temperature is **31.4 [C]** and the corresponding cooling power is **705 kW** (in place of 1MW in BAC conditions).

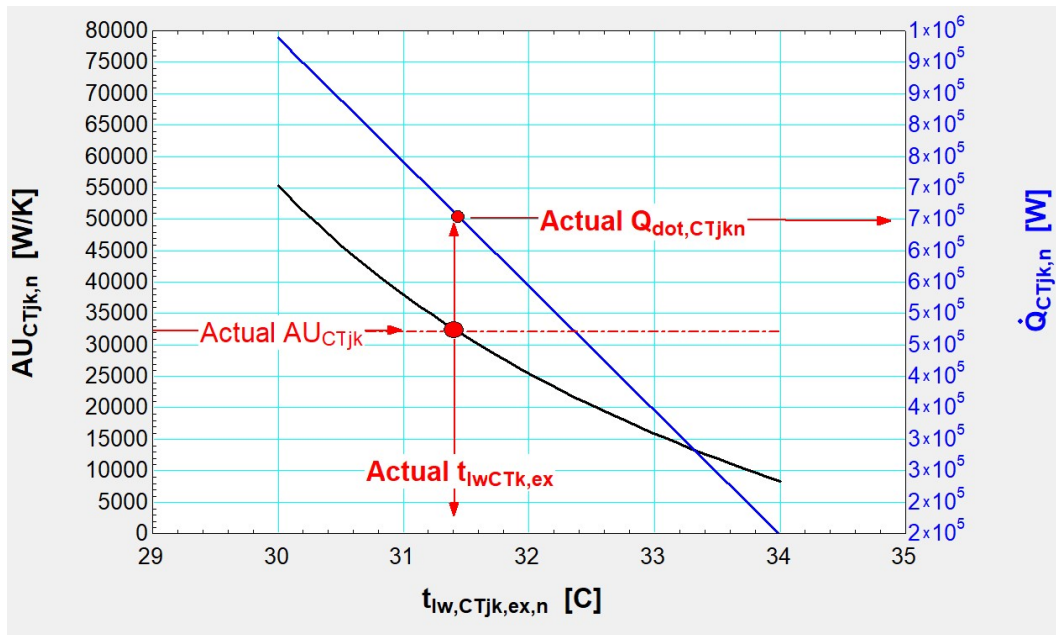

Figure 11: Identification of the cooling power in nominal conditions of the ASHRAE toolkit

As this cooling power is lower than the smallest nominal cooling power actually considered in the toolkit, any extrapolation of the regressions previously established appears as very questionable.

Indeed, both nominal air flow rate and corresponding nominal fan power appear as very much underestimated by the toolkit regressions, as shown in **Figure 12**.

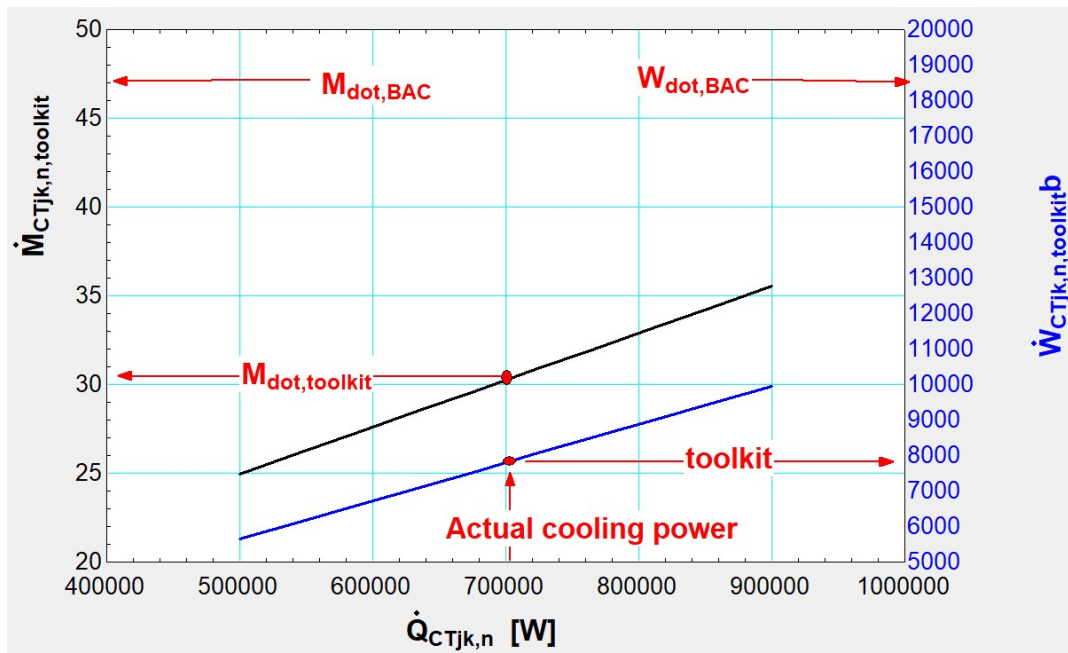

Figure 12: Identification of nominal air flowrate and of nominal fan power by extrapolations of the toolkit regressions

At the contrary, the nominal heat transfer coefficient appears as slightly overestimated in the toolkit, as shown in **Figure 13**.

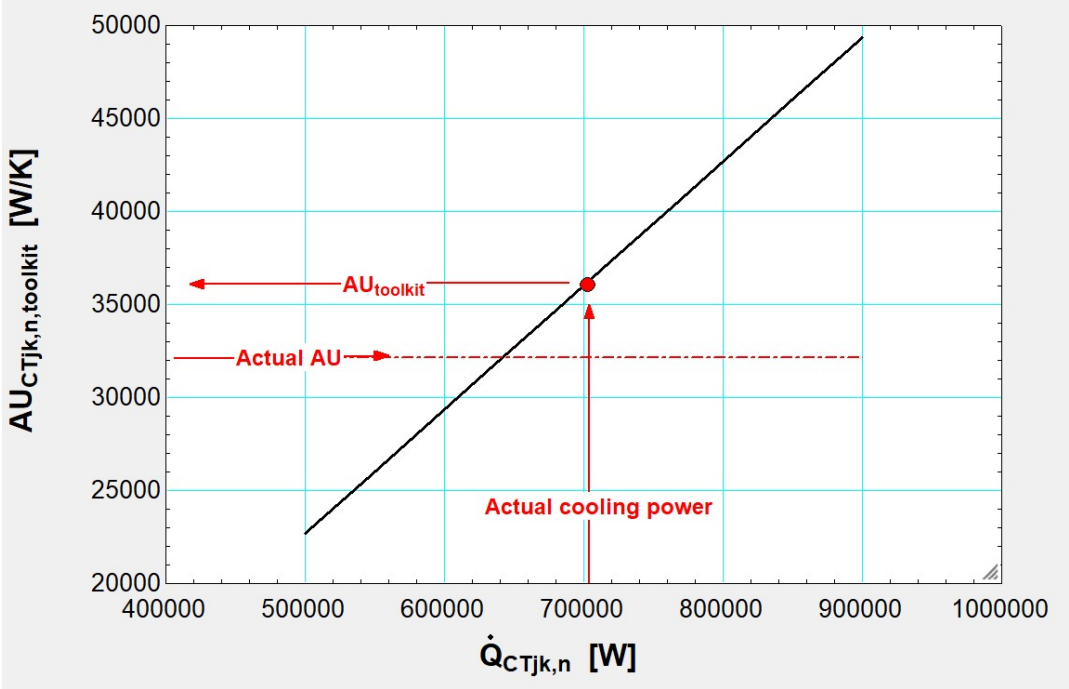

Figure 13: Identification of nominal heat transfer coefficient by extrapolations of the toolkit regression

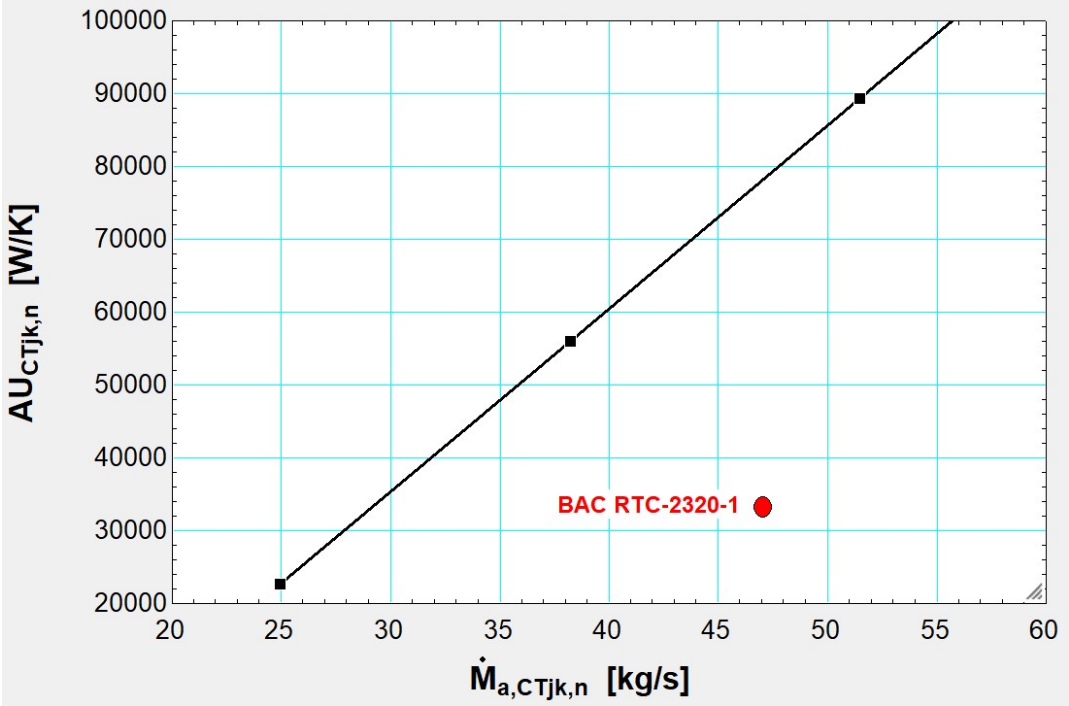

Figure 14: Identification of nominal heat transfer coefficient as function of the nominal air flow rate (toolkit regression and example of BAC cooling tower)

Such analysis obviously deserves to be extended to other (and bigger) cooling towers proposed by manufacturers!

2.3 Friction and Colburn coefficients

This set of information and hypotheses can also be used, in a same way as in the ASHRAE toolkit, to identify a global “friction factor” and a global “Colburn coefficient”

(EES file: “JL221111-01 JL221110-01 nominal conditions of the toolkit adapted to BAC handbook”):

$$\Delta p_{padding,CTjk,n} = f_{LDAfree2padding,CTjk} \rho_{CTjk,su,n} \frac{\dot{V}_{CTjk,n}^2}{2}$$

$$AU_{CTjk,n} = jPrkAwet\nuAfree_{CTjk,n} \cdot \dot{V}_{CTjk,n}$$

This gives:

$$f_{LDAfree2padding,CTjk} = 0.2191$$

And

$$jPrkAwet\nuAfree_{CTjk,n} = 769.5$$

These results are compared to ASHRAE toolkit in **Figures 15** and **16**.

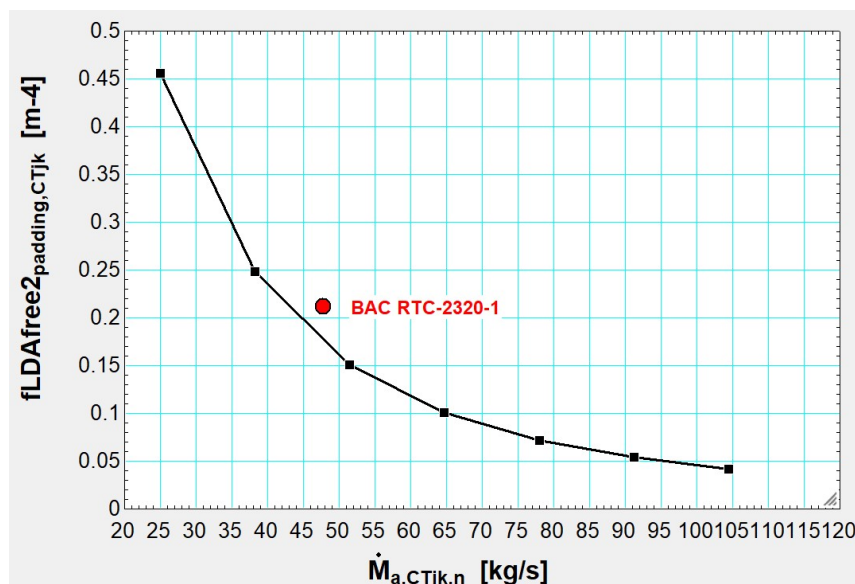

Figure 15: Nominal “friction coefficient” as function of the nominal air flow rate

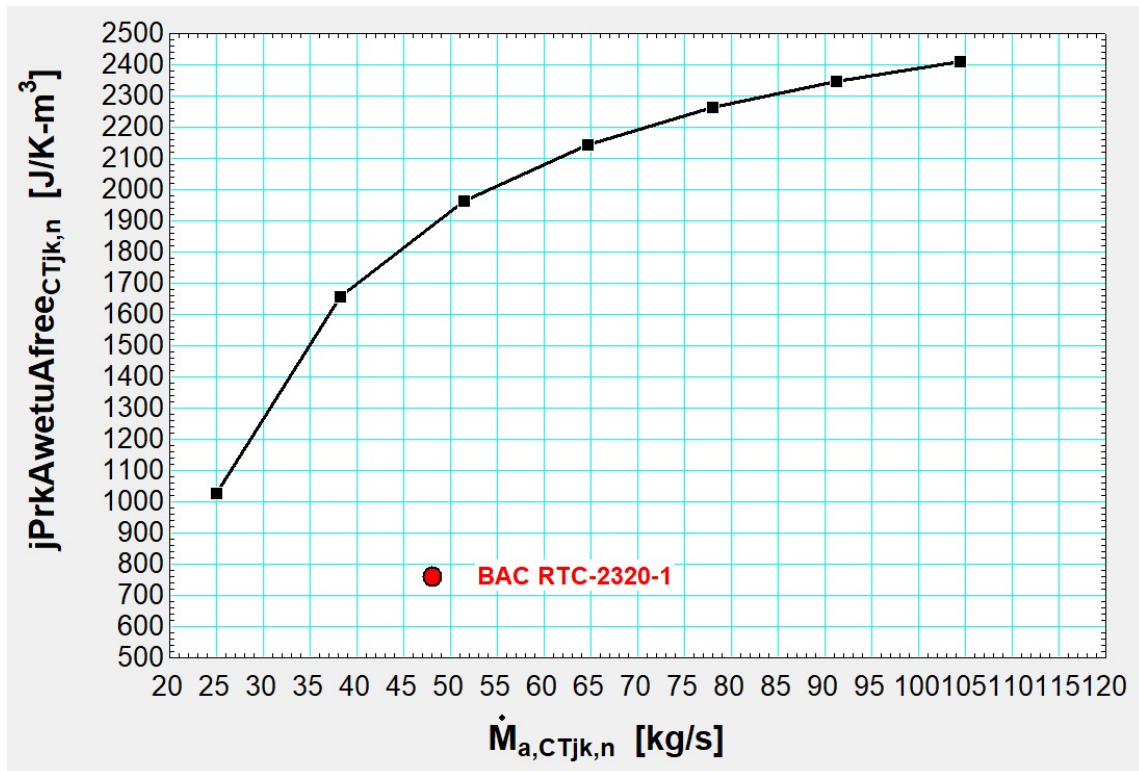

Figure 16: Nominal “Colburn coefficient” as function of the nominal air flow rate

NB:

- 1) The “agreement” observed in **Figure 15** is nothing else than a verification: the pressure drop is estimated *in same way* in the ASHRAE toolkit and in the present analysis with the *same hypothesis* about the fan efficiency.
- 2) The strong disagreement observed in **Figure 16** suggests that the present identification of the actual cooling power is probably not satisfactory...

2.4 With main sizes taken into account

The following padding sizes are considered:

$$L_{\text{padding,CTjk}} = 3.5 \text{ [m]}$$

$$W_{\text{padding,CTjk}} = 3.5 \text{ [m]}$$

$$H_{\text{padding,CTjk}} = 1 \text{ [m]}$$

Which gives access to the two other characteristics:

Padding cross area:

$$A_{\text{padding,CTjk}} = L_{\text{padding,CTjk}} W_{\text{padding,CTjk}} \text{ [m}^2\text{]}$$

Padding volume:

$$\text{Volume}_{\text{padding,CTjk}} = A_{\text{padding,CTjk}} H_{\text{padding,CTjk}}$$

This allow expressing the pressure drop by unit of padding length and the transfer coefficients by unit of padding volume (EES file: "JL221115-01 JL221111-01 BAC cooling tower in toolkit conditions"):

$$\Delta p \backslash H_{\text{padding,CTjk,n}} = \frac{\Delta p_{\text{padding,CTjk,n}}}{H_{\text{padding,CTjk}}}$$

$$AU \backslash V_{\text{padding,CTjk,n}} = \frac{AU_{\text{CTjk,n}}}{\text{Volume}_{\text{padding,CTjk}}}$$

$$AU_{m \backslash V, \text{padding,CTjk,n}} = \frac{AU \backslash V_{\text{padding,CTjk,n}}}{cp_{\text{CTjk,su,n}}}$$

$$Ka_{\text{padding,CTjk,n}} = AU_{m \backslash V, \text{padding,CTjk,n}} s \backslash h$$

$$s \backslash h = 3600 \text{ [s/h]}$$

(*Ka has the same meaning as $Aum \backslash V$, except for the time unit*)

This gives:

$$\Delta p \backslash H_{\text{padding,CTjk,n}} = 221.3 \text{ [Pa/m]}$$

and

$$K_{a_{padding,CTjk,n}} = 9204 \text{ [kg/h-m}^3\text{]}$$

The previous definition of the “global” friction and Colburn coefficients can be modified in such a way to (partially) eliminate the scale effects (EES file: JL221128-01 JL221115-01 completed):

$$\Delta p_{padding,CTjk,n} = f_{free} \frac{L}{H} \frac{A_{free}^2}{D_h} \rho_{CTjk,su,n} \frac{vel_{approach,padding,CTjk,n}^2}{2}$$

With a new global “friction coefficient”:

$$f_{free} \frac{L}{H} \frac{A_{free}^2}{D_h} = f \cdot \frac{L}{H} \cdot \frac{\left[\frac{A}{A_{free}} \right]^2}{D_h}$$

And with

$$\frac{L}{H}$$

geometrical characteristic, *constant for a given padding type*

$$\frac{\left[\frac{A}{A_{free}} \right]^2}{D_h}$$

combination of other geometrical characteristic, *increasing function of the water flow rate.*

In the present case, we get:

$$A_{padding,CTjk} = 12.25 \text{ [m}^2\text{]}$$

$$vel_{approach,padding,CTjk,n} = 3.412 \text{ [m/s]}$$

$$fL \frac{HA}{A_{free}^2} \frac{D, CT}{j k, su, n} = 33.01 \text{ [1/m]}$$

The global “Colburn coefficient” can be modified in a same way:

$$\frac{AU}{\text{Volume}} = j \Pr k \frac{A}{A_{free}} \text{Pr}_{\text{spray}} \cdot \text{vel}_{\text{approach}}$$

With a new global “Colburn coefficient”:

$$j \Pr k \frac{A}{A_{free}} \text{Pr}_{\text{spray}} = j \cdot \text{Prandtl} \cdot \frac{k}{v} \cdot \alpha \cdot \frac{A}{A_{free}} \cdot \epsilon_{\text{spray}}$$

And with

$$\frac{A}{A_{free}} \cdot \epsilon_{\text{spray}} \quad \text{increasing function of the water flow rate.}$$

In the present case, we get:

$$j \Pr k \frac{A}{A_{free}} \text{Pr}_{\text{spray}} = 768.5 \text{ [J/K-m}^4\text{]}$$

3. Information produced by another manufacturer [3]

3.1 Manufacturer data

The geometries of two different padding types are shown in **Figures 17** and **18**.



Figure 17: Padding 1 (type S) **Figure 18:** Padding 2 (oblique refraction)

According to this manufacturer, the pressure drops and mass transfer coefficients generated by these two padding types are to be identified through the following regressions:

Pressure drop of Paddings: $\Delta P = 9.81 \cdot a \cdot v_a^m$

padding I: $a = -0.0017 \cdot q^2 + 0.0652 \cdot q + 0.6124$; $m = 0.0023 \cdot q^2 - 0.0522 \cdot q + 2.0273$ (height=1m)
 $a = -0.0015 \cdot q^2 + 0.0516 \cdot q + 0.9044$; $m = 0.0001 \cdot q^2 - 0.0008 \cdot q + 2.0018$ (height=1.25m)
 $a = -0.0013 \cdot q^2 + 0.0483 \cdot q + 1.1074$; $m = 0.0001 \cdot q^2 - 0.0006 \cdot q + 2.0019$ (height=1.5m)

padding II: $a = -0.0002 \cdot q^2 + 0.0321 \cdot q + 0.9614$; $m = -0.0001 \cdot q^2 - 0.0002 \cdot q + 2.0034$ (height=1m)
 $a = -0.001 \cdot q^2 + 0.0424 \cdot q + 1.0679$; $m = 0.0001 \cdot q^2 - 0.0027 \cdot q + 1.9994$ (height=1.25m)
 $a = -0.0004 \cdot q^2 + 0.0329 \cdot q + 1.1867$; $m = 0.0001 \cdot q^2 - 0.0018 \cdot q + 1.9974$ (height=1.5m)

With v_a = “approach air velocity” [m/s]

q = “approach (and fictitious) water velocity” [m/h] (not in m/s!)

The exponent “m” very near to 2, whatever is the (constant) water flow rate. This confirms the turbulent regime: the *friction factor (“f”)* stays *almost constant*.

The water flow rate mainly affects (but slowly) the coefficient “a” and not the exponent m. This effect appears as almost linear; as already indicated, it should correspond to the obstruction produced by the liquid water falling through the padding. It should correspond to a variation of the combination of geometrical characteristics

$$\frac{\left[\frac{A}{A_{\text{free}}} \right]^2}{D_h}$$

Contained in the global friction coefficient.

Mass transfer coefficient of Paddings $Ka = C \cdot g^{a_1} q^{b_1}$

Mass transfer coefficient of padding I: $C = 4488$, $a_1 = 0.6$, $b_1 = 0.41$; (height=1m)
 $C = 4055$, $a_1 = 0.65$, $b_1 = 0.38$; (height=1.25m)
 $C = 3713$, $a_1 = 0.59$, $b_1 = 0.39$; (height=1.5m)

Mass transfer coefficient of padding II: $C = 4508$, $a_1 = 0.68$, $b_1 = 0.36$; (height=1m)
 $C = 3917$, $a_1 = 0.62$, $b_1 = 0.39$; (height=1.25m)
 $C = 3839$, $a_1 = 0.63$, $b_1 = 0.35$; (height=1.5m)

With g = approach air “mass velocity” [kg/sm²]

The constant “C” appears as a (slow) decreasing function of the padding height.

The exponents of both velocities are not affected by the padding height.

The positive effect of liquid water flow rate probably corresponds to an increase of the factor

$$\frac{A}{A_{\text{free}}} \cdot \varepsilon_{\text{spray}}$$

Contained in the Colburn coefficient.

3.2 Analysis

(EES files: “JL221121-01 JL220621-01 slide 6 effect of air flow rate” and “JL221121-02 JL220621-02 slide 6 effect of water flow rate”)

3.2.1 Examples considered

Examples of application of these regressions are presented in **Table 3**.

Height of paddings (m)	Air velocity v_a (m/s)	Spraying density of water (t/h/m ²)	Air mass velocity g (kg/m ² /s)	Water volumetric velocity q (m ³ /h/m ²)	Mass transfer coefficient of padding I Ka (kg/m ³ /h)	Mass transfer coefficient of padding II Ka(kg/m ³ /h)	Padding I a	Padding I m	Pressure drop of padding I (Pa)	Padding I a	Padding II m	Pressure drop of padding II (Pa)
1	2.77	10	3.324	10	23716.43772	23341.83426	1.0944	1.7353	62.90428568	1.2624	1.9914	94.19334
1.25	2.77	10	3.324	10	21235.89251	20248.05915	1.2704	2.0038	95.99540688	1.3919	1.9824	102.908
1.5	2.77	10	3.324	10	18514.19988	18317.43047	1.4604	2.0059	110.588763	1.4757	1.9894	109.8845

Table 3: examples of calculation [3]

Both the “approach air velocity” and the corresponding air/water ratio are here of the same order of magnitude as with the BAC cooling tower **in nominal conditions:**

$$\text{Airvelpadd}=2.77 \text{ [m/s]}$$

in place of 3.4

$$\text{Mflowratio}=1.197 \text{ [-]}$$

in place of 1 (hypothetical!)

With an height of 1 [m], both padding types (“1” and “2”) appear as generating *much lower pressure drops* (63 and 94 in place of 221 [pa]) *and much higher mass transfer coefficients* (23716 and 23341 in place of 9204 [kg/m³h]) than the BAC cooling tower.

As it will be shown hereafter, experimental results suggest that these manufacturer’s regressions might be a bit *optimistic*...

3.2.2 Pressure drops

Some of the results obtained with previous regressions are plotted in **Figures 19 to 24**.

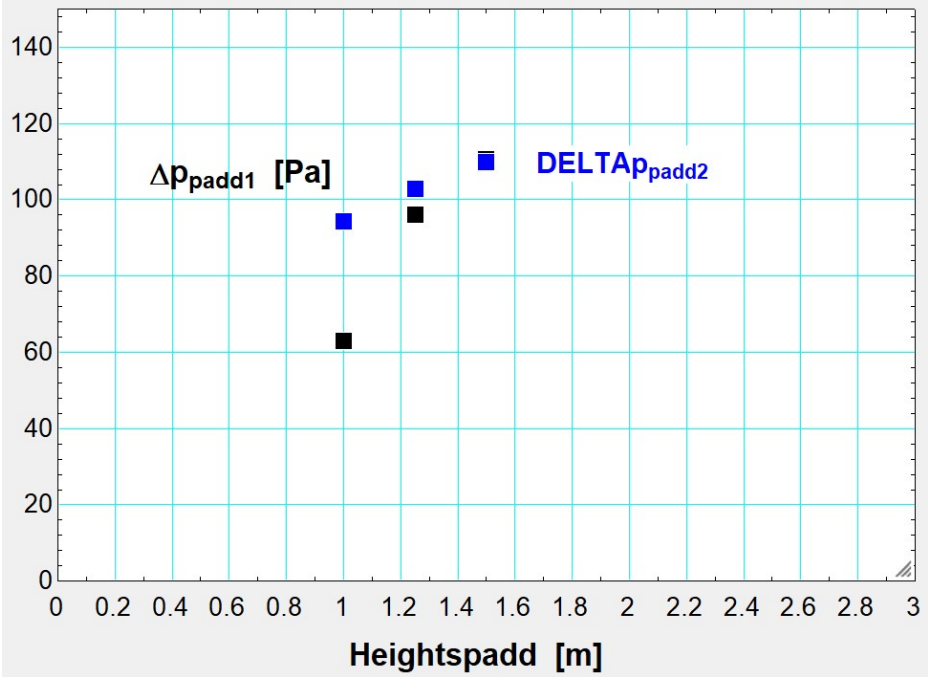

Figure 19: Effect of padding height on air pressure drop

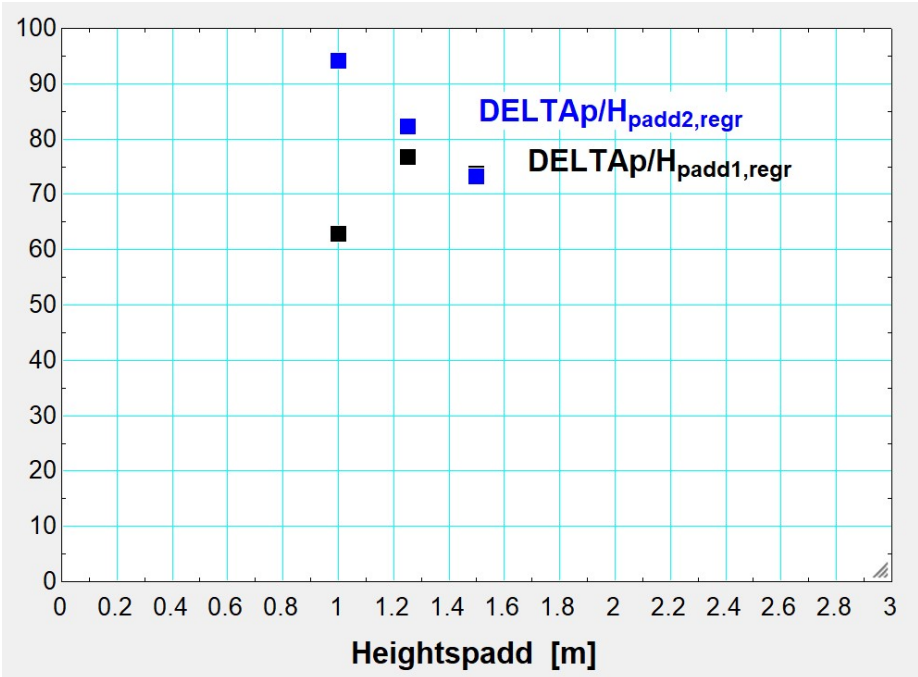

Figure 20: Effect of padding height on “specific” air pressure drop

With **padding 1**, the pressure drop may appear as more or less proportional to the height, but this not true with **padding 2**. Some decrease of the “specific” pressure drop ($\Delta P_{padd}/H$) as function of the padding height could be explained by the impact of some local pressure drop at padding supply, but this has still to be confirmed...

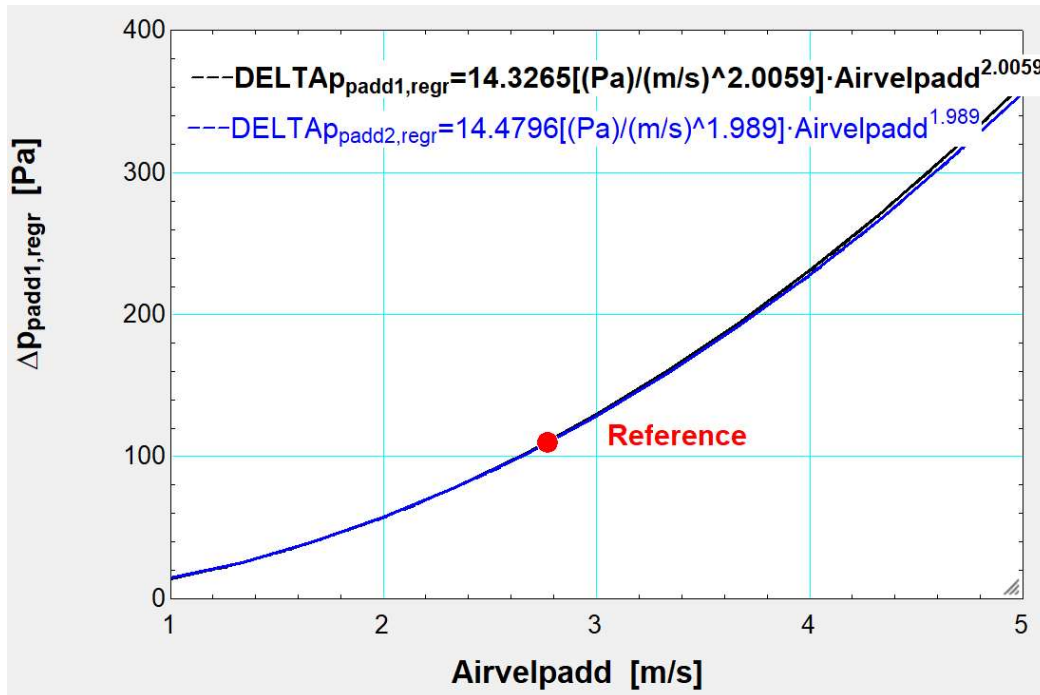

Figure 21: effect of air velocity on pressure drop, with **H=1.5 m** and **spray density of 10 T/m²h**

The “no significant variation” of the friction factor “f” (at constant water flow rate) is here confirmed.

The following (almost the same and constant) **friction coefficients** are identified with the reference spray density of **10 T/m²h**:

$$f_{L\backslash HAA_{free2D,padd1}} = 16.01 \text{ [1/m]}$$

$$f_{L\backslash HAA_{free2D,padd2}} = 15.91 \text{ [1/m]}$$

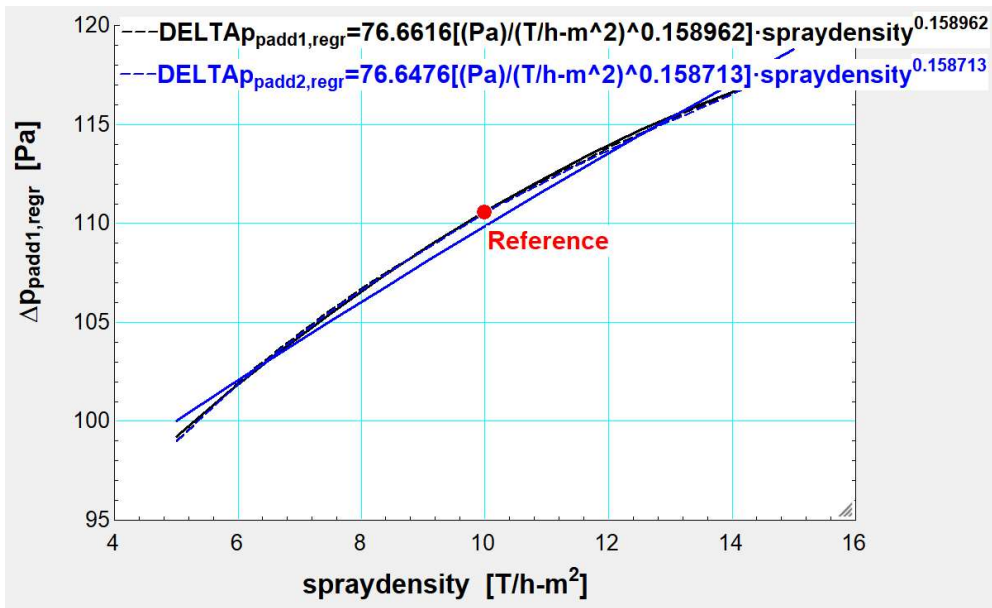

Figure 22: effect of spray density on pressure drop, with $H=1.5$ [m] and air velocity of 2.77 [m/s]

A significant increase of the coefficient

$$\frac{\left[\frac{A}{A_{\text{free}}} \right]^2}{D_h}$$

With the water flow rate is here confirmed. The corresponding friction coefficient is plotted in **Figure 23**.

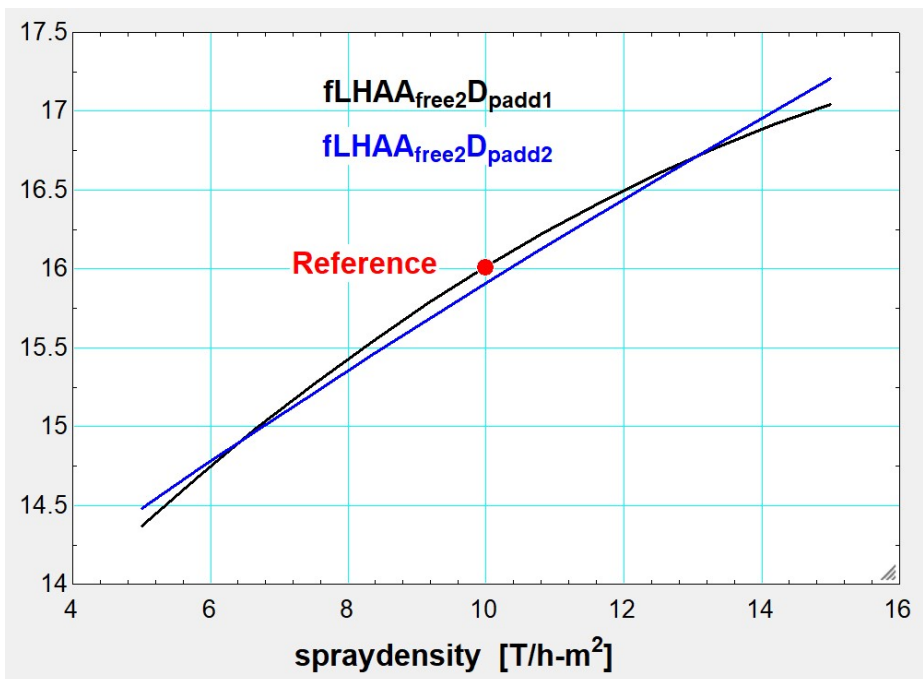

Figure 23: effect of the spray density on the friction coefficient

This variation of friction coefficient due to the water spray can also be expressed in relative value:

$$\text{SprayFratio}_{\text{padd1}} = \frac{fL\backslash HAA_{\text{free2}\backslash D,\text{padd1}}}{fL\backslash HAA_{\text{free2}\backslash D,\text{padd1,ref}}}$$

$$\text{SprayFratio}_{\text{padd2}} = \frac{fL\backslash HAA_{\text{free2}\backslash D,\text{padd2}}}{fL\backslash HAA_{\text{free2}\backslash D,\text{padd2,ref}}}$$

with

$$fL\backslash HAA_{\text{free2}\backslash D,\text{padd1,ref}} = 16.01$$

$$fL\backslash HAA_{\text{free2}\backslash D,\text{padd2,ref}} = 15.91$$

And with the reference conditions:

$$\text{vel}_{\text{approach}} = 2.77 \text{ [m/s]} \quad \text{sprayedensity}_{\text{ref}} = 10 \text{ [T/h-m}^2\text{]}$$

$$\text{water}_{\text{vel,approach}} = 0.002778 \text{ [m/s]}$$

The “SprayFratio “ is also plotted in **Figure 24** as function the ratio between actual and reference water velocities:

$$\text{water}_{\text{vel,ratio}} = \frac{\text{water}_{\text{vel,approach}}}{\text{water}_{\text{vel,approach,ref}}}$$

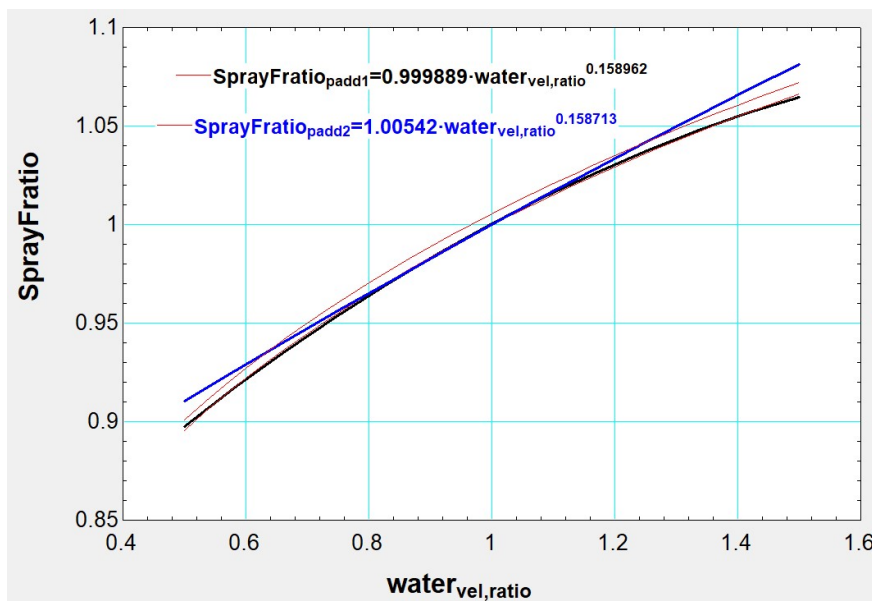

Figure 24: Effect of the spray density on the friction coefficient with both variables expressed in *relative* values

3.2.3 Transfer coefficients

3.2.3.1 As function of the air velocity

Some of the results obtained with previous regressions are plotted in **Figures 25 to 27**.

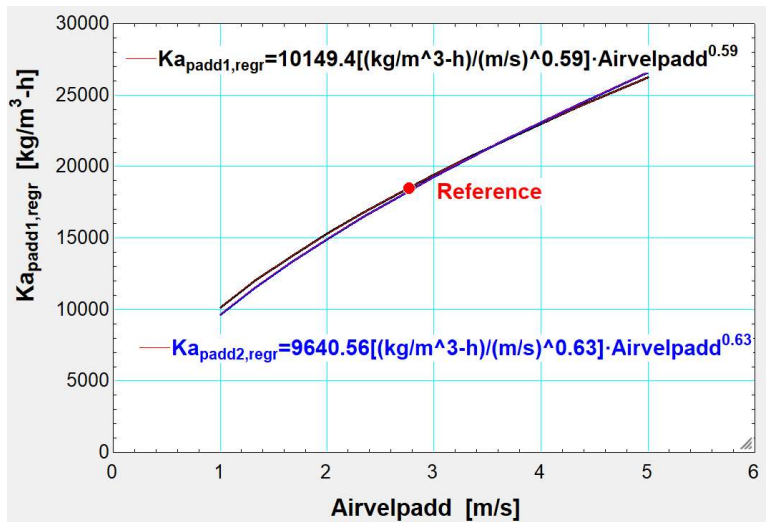

Figure 25: mass transfer coefficient function of air velocity (with $H=1.5\text{m}$ and spray density of $10 \text{ T/m}^2\text{h}$)

This result suggests that the Colburn factor “j” is significantly decreasing, even in turbulent regime. The Colburn coefficient is plotted in **Figure 26**.

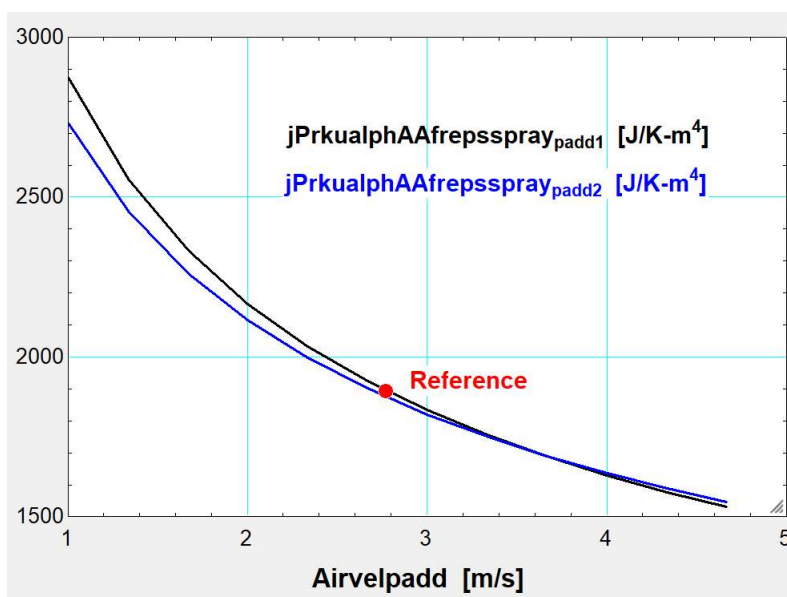

Figure 26: effect of the air velocity on the Colburn Coefficient

This gives in reference conditions:

$$j_{Prk} \backslash n_{\alpha} \backslash A \backslash f_{rep} \backslash s_{spray} \backslash padd1 = 1894 \text{ [J/K-m}^4\text{]}$$

$$j_{Prk} \backslash n_{\alpha} \backslash A \backslash f_{rep} \backslash s_{spray} \backslash padd2 = 1874 \text{ [J/K-m}^4\text{]}$$

The relative effect of air velocity is plotted in **Figure 27**, with

$$velColburnratio_{padd1} = \frac{Colburncoeff_{padd1}}{Colburncoeff_{padd1,ref}}$$

$$velColburnratio_{padd2} = \frac{Colburncoeff_{padd2}}{Colburncoeff_{padd2,ref}}$$

$$velpadd = \frac{Massairvelpadd}{\rho}$$

$$velpaddratio = \frac{velpadd}{velpadd_{ref}}$$

with

$$velpadd_{ref} = 2.77 \text{ [m/s]}$$

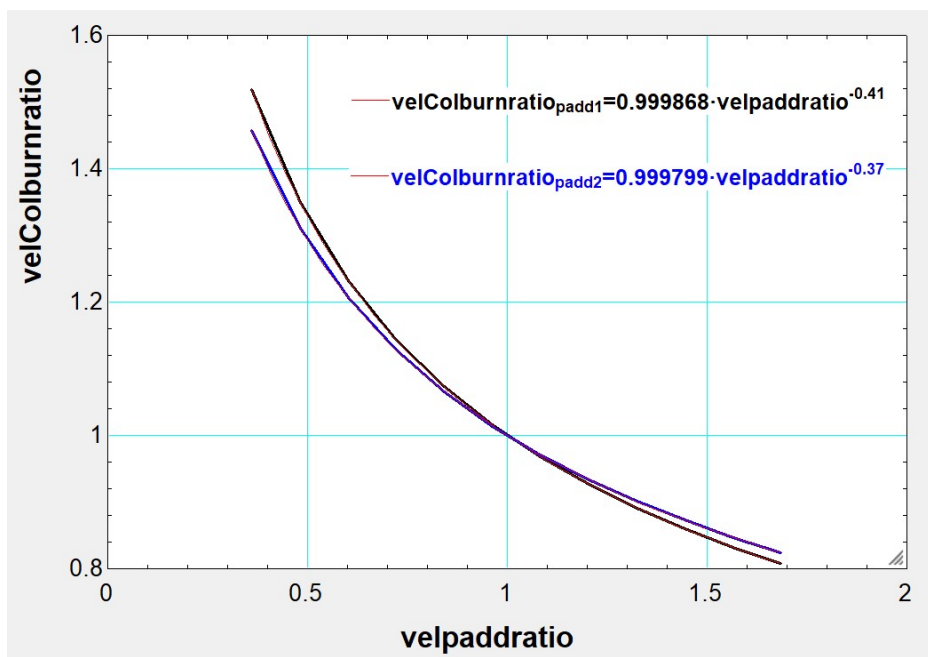

Figure 27: relative effect of the air velocity on the Colburn Coefficient

3.2.3.2 As function of the **water** velocity

Some of the results obtained with previous regressions are plotted in **Figures 28** to **30**.

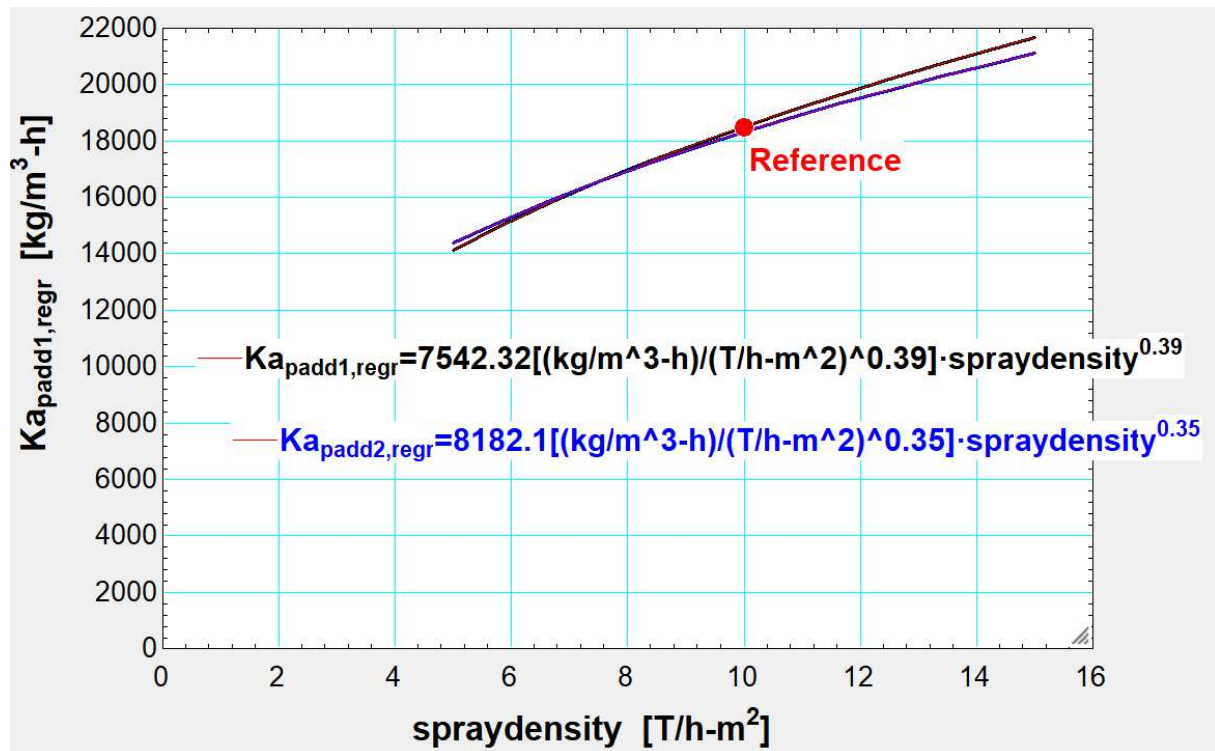

Figure 28: effect of spray density on mass transfer coefficient, with $H=1.5$ [m] and air velocity of 2.77 [m/s]

(EES file: JL221121-02 JL220621-02 slide 6 effect of water flow rate)

This increase of the transfer coefficient at constant air flow rate, confirms the positive effect of the water flow rate on the coefficient

$$\frac{\left[\frac{A}{A_{\text{free}}} \right]^2}{D_h}$$

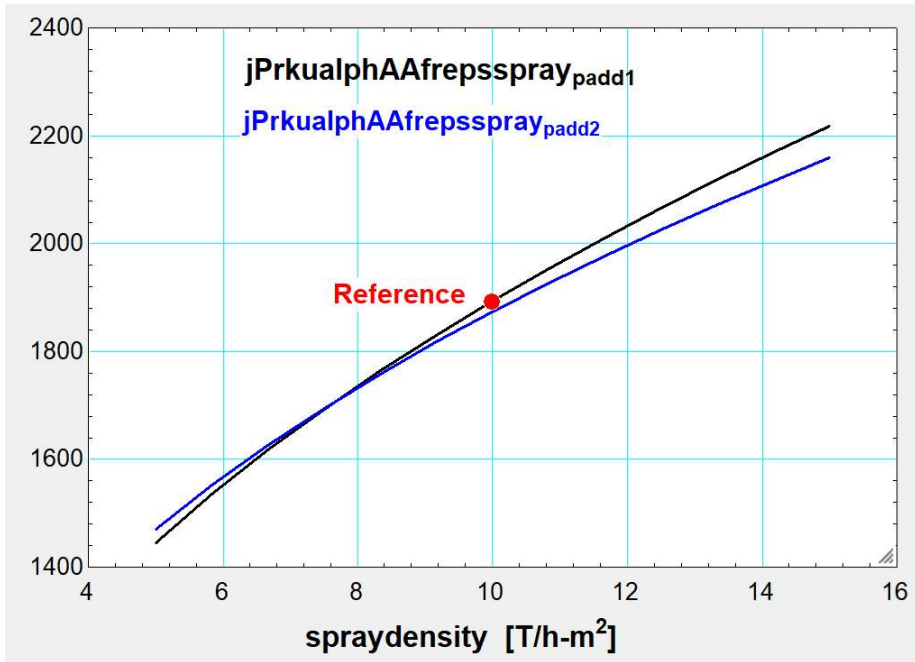

Figure 29: effect of the spray density on the Colburn coefficient

The *relative* effect is plotted in **Figure 30**, with

$$\text{SprayColburnratio}_{\text{padd1}} = \frac{\text{Colburncoeff}_{\text{padd1}}}{\text{Colburncoeff}_{\text{padd1,ref}}}$$

$$\text{SprayColburnratio}_{\text{padd2}} = \frac{\text{Colburncoeff}_{\text{padd2}}}{\text{Colburncoeff}_{\text{padd2,ref}}}$$

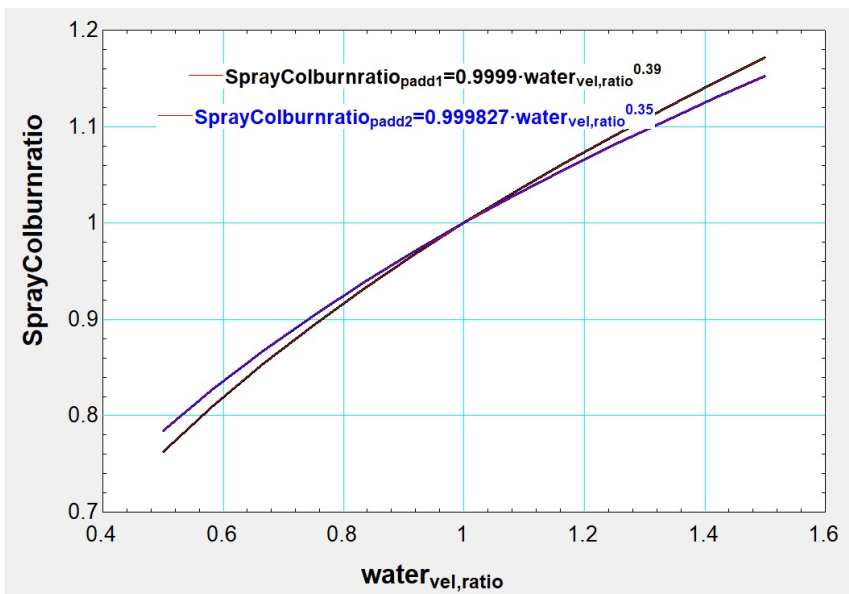

Figure 30: *relative* effect of the water velocity on the Colburn coefficient

NB: The effects of both (air and water) flow rates are probably not independent: increasing the air flow rate with *constant* water flow rate is probably producing a decrease of spray effectiveness.

This seems to be suggested by the “complementarities” of the exponents of the power regressions of **Figures 25** and **28** and also of **Figure 27** and **30**.

In other terms, the water velocity effect could be perhaps better observed with the flow mass ratio as independent variable. And at constant flow mass ratio, the Colburn coefficient would appear as almost constant, as to be expected in fully turbulent regime...

4. Experimental results [3]

4.1 Results obtained with two paddings

These results are presented in **Tables 4** and **5**.

The two paddings are of type “**S**”, as padding “1” already described by the manufacturer.

They only differ by their lengths (11 m in case 1 and 20 m in case 2).

Their height (3 m) is much higher than previously considered.

The atmospheric pressure is slightly reduced (93.2 in place of 101.325 Pascal).

- Case I: testing results of padding performance in one indirect evaporative chiller
 Padding size: 11m (length)* 2m(width)*3m(height)
 Padding type: countercurrent padding, S type padding
 Atmospheric pressure: 93.2 kPa

Testing working conditions	Air flow rate (m3/h)	Water flow rate (m3/h)	Windward section area	Height of paddings (m)	Spraying density of water (t/h/m2)	Water volumetric velocity q (m3/h/m2)	Air mass velocity g (kg/m2/s)	Spraying water temperature (°C)	Testing outlet water temperature (°C)	Calculated outlet water temperature (°C)	Inlet air temperature of paddings (°C)	Inlet air humidity ratio of paddings (kg/kg air)	Exhaust air temperature (°C)	Exhaust air relative humidity (%)	Exhaust air enthalpy (kJ/kg)	Mass transfer coefficient of padding Ka (kg/m3/h)
1	71152	97.6	22	3	4.44	4.4	0.99	18.6	15.5	15.6	17.4	0.008512	19.4	93.5	55.97	6295
2	71152	97.6	22	3	4.44	4.4	0.99	18.4	15.1	15.4	17.1	0.008668	18.7	96.7	54.88	8760
3	71152	77.4	22	3	3.52	3.5	0.99	18.6	14.4	15.4	17.0	0.008555	18.2	95.9	52.93	4385
4	71152	77.4	22	3	3.52	3.5	0.99	18.4	14.3	14.7	16.8	0.008252	18.7	94.5	54.04	6278

Table 4: Results obtained in case 1

- Case II: testing results of padding performance in another indirect evaporative chiller
 Padding size: 20m (length)* 2m(width)*3m(height)
 Padding type: countercurrent padding, S type padding

Atmospheric pressure (kPa)	Air flow rate (m3/h)	Water flow rate (m3/h)	Windward sectional area (m2)	Height of paddings (m)	Spraying density of water (l/h/m2)	Water volumetric velocity q (m3/h/m2)	Air mass velocity (kg/m2/s)	Spraying water temperature (°C)	Testing outlet water temperature (°C)	Inlet air temperature of paddings (°C)	Inlet air humidity ratio of paddings (kg/kg air)	Exhaust air temperature (°C)	Exhaust air wet bulb temperature (°C)	Exhaust air enthalpy (kJ/kg)	Calculated air enthalpy (kJ/kg)	Mass transfer coefficient of padding Ka (kg/m3/h)
93.2	217600	241.6	40	3	6.04	6.04	1.66	20.65	15.6	19.75	0.007206	20.85	20.13	61.2	59.24	7455

Pressure drop testing

Pressure drop of air coolers (Pa)	Pressure drop of paddings (Pa)	Number of rows of air cooler	Height of padding (m)	Pressure drop of air cooler (Pa/ 1 row)	Pressure drop of paddings (Pa/m)
103.5	94.1	8	3	13	31

Table 5: Results obtained in case 2

4.2 Analysis of case 1 (EES file: JL221204-01 JL220716-01 JL220709-01 slide 7 corrected):

If keeping the hypothesis of independent effects of both (air and water) flow rates, one may calculate the Colburn coefficient with the following model (EES file: "JL221209-01 Padding type 1")

$$\text{Colburncoeff} = \text{Colburncoeff}_{\text{ref}} \cdot \text{velColburnratio} \cdot \text{SprayColburnratio}$$

With

$$\text{velColburnratio} = 0.9999 \cdot \text{velratio}^{-0.41}$$

$$\text{SprayColburnratio} = 0.99989967 \cdot \text{water}_{\text{vel,ratio}}^{0.39}$$

$$\text{velratio} = \frac{\text{vel}_{\text{approach}}}{\text{vel}_{\text{approach,ref}}}$$

$$\text{water}_{\text{vel,ratio}} = \frac{\text{water}_{\text{vel,approach}}}{\text{water}_{\text{vel,approach,ref}}}$$

$$\text{Colburncoeff}_{\text{ref}} = 1894 \text{ [J/K-m}^4\text{]}$$

$$vel_{\text{approach,ref}} = 2.77 \text{ [m/s]}$$

$$water_{\text{vel,approach,ref}} = 0.002778 \text{ [m/s]}$$

The different transfer coefficients are then obtained as follows:

$$AU\backslash V = \text{Colburncoeff} \cdot vel_{\text{approach}}$$

$$AU_{m\backslash V} = \frac{AU\backslash V}{cp}$$

$$Ka_{\text{model}} = AU_{m\backslash V} \cdot s\backslash h$$

$$s\backslash h = 3600 \text{ [s/h]}$$

The main results are presented in **Table 6**.

1	2	3	4	5	6	7	8
Test	airflowrate	waterflowrate	velColburnratio	SprayColburnratio	Colburncoeff	Ka _{model}	Ka
[-]	[m ³ /h]	[m ³ /h]					[kg/m ³ -h]
1	71152	97.6	1.588	0.7259	2183	6910	6295
2	71152	97.6	1.588	0.7259	2183	6910	8760
3	71152	77.4	1.588	0.6639	1996	6320	4385
4	71152	77.4	1.588	0.6639	1996	6320	6278

Table 6: Modelling of Ka compared with new experimental results

It appears the model is in fair agreement with these new experimental results, but not explaining the strong variations of the mass transfer coefficient.

4.3 Analysis of case 2 (EES file: JL221209-03 JL220717-01 corrected JL220625-02 slide 8):

The comparison on the transfer coefficients is performed in the same way as in case 1:

$$\text{airflowrate} = 217600 \text{ [m}^3\text{/h]} \quad \text{waterflowrate} = 241.6 \text{ [m}^3\text{/h]}$$

$$\text{velColburnratio} = 1.284 \quad \text{SprayColburnratio} = 0.8214$$

$$\text{Colburncoeff} = 1998 \text{ [J/K-m}^4\text{]}$$

$$Ka_{\text{model}} = 10606 \text{ [kg/m}^3\text{-h]} \quad Ka = 7455 \text{ [kg/m}^3\text{-h]}$$

In this case, the previous model is significantly overestimating the transfer coefficient.

A comparison between pressure drops is also possible with the previous model (EES file: "JL221209-01 Padding type 1"):

$$\text{SprayFratio} = 0.9229$$

$$fL\backslash HA\backslash A_{\text{free2}\backslash D} = 14.78 \text{ [1/m]}$$

$$\Delta p\backslash H_{\text{model}} = 18.44 \text{ [Pa/m]} \quad \Delta p\backslash H = 31 \text{ [Pa/m]}$$

And it seems that the model is underestimating the pressure drop...

5. Conclusions

No conclusion yet; this work should be continued and more experimental results are very welcome!

6. References

- [1] ASHRAE 1993. "A Toolkit for primary HVAC Energy calculations"
- [2] BAC Product and applications handbook EU volume I 2006
- [3] Xiaoyun Xie, Ce Zhao, Yi Jiang : "Testing performance of IEC water chiller and components" Tsinghua University, Beijing, China 2022.7

Jean Lebrun, Liège, December 10th 2022
